

## Thermal & Cable Solutions

**A250C+/A450C+ PL/TL/VD**  
Non-contact Infrared Pyrometers

### USER MANUAL



**TEMPSENS INSTRUMENTS (I) PVT. LTD.**

B-188A, Road No.5, Mewar Industrial Area (M. I. A.),  
Madri, Udaipur-313003 (Rajasthan) INDIA  
**Ph.:+91-9116554600, Email: info@tempsens.com**

---

# Index

<b>1. Chapter - 1</b> .....	<b>1</b>
General information	
<b>2. Chapter - 2</b> .....	<b>2</b>
Introduction	
2.1 Product Key Features, Application and Range	
2.2 Technical specification	
2.3 Optics	
<b>3. Chapter - 3</b> .....	<b>6</b>
Basics & Installation of Pyrometer	
3.1 Basics of Infrared temperature measurement of an object	
3.2 Installation	
3.3 Location Selection	
3.4 Mechanical Accessories	
3.5 Electrical Installation	
<b>4. Chapter - 4</b> .....	<b>14</b>
Setting at the Instruments	
4.1 Operation	
4.2 Key Descriptions	
4.3 Adjustable Parameters	
4.4 Other Parameters	
<b>5. Chapter - 5</b> .....	<b>18</b>
Software installation	
4.1 Installation	
4.2 Parameters in main screen	
<b>6. Chapter - 6</b> .....	<b>25</b>
Maintenance	
<b>7. Chapter - 7</b> .....	<b>26</b>
Serial communication protocol	
<b>8. Appendix B</b> .....	<b>31</b>
<b>9. Appendix C</b> .....	<b>33</b>

---

# Chapter - 1

## General Information

Congratulations on choosing this high quality and highly efficient Tempsens pyrometer for non contact temperature measurement.

Please read this user manual carefully, step by step, including all notes of security, operation and maintenance before installing the pyrometer. This manual contains all the necessary instructions for set up and operation of the pyrometer. This section provides an overview about important safety regulations.

### Some Important Safety Regulations Given Below

#### 1. Safety Precaution

Each person working with pyrometer must read the user manual before operation. The pyrometer has only to be used for the purpose described in manual. The pyrometer works only with a potential free low voltage of range 24VDC. This voltage is not harmful for user. The pyrometer may contain harmful material and hence it should not be disposed of with normal waste.

#### 2. Packaging and Storage

Always use a shock proof package for shipment of pyrometer. It should be sealed to protect it against humidity. Also protect the lens of pyrometer with cover. They should be stored at the temperature range from -20°C to 70°C.

#### 3. Limit of Liability and Warranty

All general information and notes for handling, maintenance and cleaning of this instrument are offered according to the best of our knowledge and experience.

Tempsens reserves the right to revise this document and to make change from time to time in the content hereof without obligation to notify any person or persons of such revisions or changes

Tempsens instruments have a warranty of two year from the invoice date. This warranty covers manufacturing defects and faults which arise during operation only if they are the results of defects caused by AST.

Tempsens does not accept liability for any damages or losses which might occur, including consequential damages and financial losses, as a result of use of the instrument.

#### 4. Copyright

All rights reserved . this document may contain proprietary information and shall be respected as a proprietary document to Tempsens with permission for review and usage given only to the rightful owner of the instrument with which this document is associated.

---

# Chapter - 2

## Introduction

A250C+/A450C+ PL/TL/VD is digital two color pyrometer which uses ratio of two adjacent wavelengths for temperature measurement of target object. They are specially designed highly accurate digital pyrometers to provide high performance and low maintenance of non contact temperature measurement in demanding industrial environment.

### 2.1 Product Key Features, Application and Range

The A250C+/A450C+ PL/TL/VD pyrometers are especially designed for industrial purposes. They are suitable for high temperature measurement ranging from 475°C to 2500°C.

These pyrometers have solid body in stainless steel housing, which provides high operation safety even in rough industrial environment, and large variety of focusable optics which can be easily used in all industrial areas.

These pyrometers have OLED display which shows temperature and provides menu selection via parameterization keys. A250C+/A450C+ PL/TL/VD both are having a fast response time of 2msec. The Pyrometer provided with bluetooth for communication between pyrometer & Android mobile, RS-485 for long distance communication between pyrometer & PC software Infracore. Response time, emissivity, sub-range and peak picker selection can be preset ex-works or adjustable through available software.

The A250C+/A450C+ PL/TL/VD pyrometers are suitable for industrial purpose due to following advantages:

- Measurement of temperature is not affected by emissivity of object.
- Measurement of object temperature is possible where dust, moisture & other contaminants are present in surrounding environment.
- The measuring object can be smaller than spot size.
- The pyrometer can be switched between 1-colour & 2-colour mode.

Temperature measurement can be taken in any of the following modes:

1. Single colour mode.
2. Two colour mode.

**Single Colour Mode:** Single colour mode is best for measuring the temperature of target object in areas where no sighting obstacle is present between the target object and the pyrometer. Sighting obstacle can be any solid item, gaseous particles, smoke and dust etc. This mode is very useful where target object completely fills the spot size.

**Two colour Mode:** The basic concept of two colour mode is temperature measurement of the target object is done by the ratio of two separate and overlapping of infrared bands. Two sensors are used in this type of pyrometer.

### 2.2 Operational Theory for 2-colour sensors

Accurate and repeatable temperature measurement is possible with the two colour ratio technology that does not depend on emissivity of object. Basically a 2 colour sensor determines temperature from the ratio of radiated energies in two separate wavelength bands (2 different colours).

Advantages of two colour pyrometer over single colour pyrometer which makes it suitable for industrial usage are as follows:

- Measurement of temperature is not affected by emissivity of object.
- Measurement of object temperature is possible where dust, moisture and other contaminants are present in surrounding environment.
- The measuring object can be smaller than the spot size.
- The pyrometer can be switched between 1-colour and 2-colour mode.
- The spot is partially blocked or obscured.

### 2.2.1 Measurement of temperature is not affected by low or changing emissivity values

If the value of emissivity in both colours (wavelengths) are same as like for the black body (where emissivity =1.0) or for grey body where emissivity is less than 1.0 but a constant number and the emissivity of the target would not get influenced. But actually grey body does not exist in nature. The emissivity of all real objects changes with temperature and wavelength at variable degrees, depending on the material. 2 colour pyrometer is more accurate than single colour pyrometer when emissivity is uncertain or changing but emissivity should change by same factor in both wavelength bands. Accuracy of result measurement is dependent on the type of material being measured and the application for which it is used.

### 2.2.2 The measuring object is smaller than spot size

If the target object is moving or it is smaller than the spot size, the amount of radiated energy is also reduced. But the ratio of energies is unaffected and hence the measured temperature remains accurate.

### 2.2.3 The spot is partially blocked or obscured

The energy emitted from a target is usually reduced when target object is being blocked or some portion of the optical head is blocked. But the ratio of the energies is not affected and hence the measured temperature remains extremely accurate.

2 colour pyrometer is better than 1 or single colour in the following conditions:-

- When path of sight is partially blocked.
- When any of the sensors is subjected to dirt and/ or moisture, smoke accumulating on the lens surface.
- When dirt, smoke & moisture is present in the atmosphere between the sensor and target.

The pyrometer temperature measurement method utilizes the fact that objects emit thermal radiation in an amount that directly corresponds to their own temperature and surface emissivity. Two color pyrometer involves measuring thermal radiance at two different wavelengths and inferring the temperature from the ratio of these spectral radiances. Radiance ratio thermometers can be significantly more accurate than single band thermometers in many applications.

The pyrometer sensor detects the amount of infrared radiation emitted by the measured object (target). The infrared signal is analyzed and the temperature it represents is analyzed by built-in microprocessor.

### The applications in which Tempens pyrometers can be used are

- |              |               |
|--------------|---------------|
| ✓ Preheating | ✓ Melting     |
| ✓ Annealing  | ✓ Sintering   |
| ✓ Tempering  | ✓ Soldering   |
| ✓ Welding    | ✓ Rolling     |
| ✓ Forging    | ✓ Brazing     |
| ✓ Hardening  | ✓ Normalizing |

### Standard Item supplied with A250C+/A450C+ PL/TL/VD

- |                                           |                              |
|-------------------------------------------|------------------------------|
| ✓ Tempens pyrometer                       | ✓ Manual                     |
| ✓ Connection cable 12-core (length - 5 m) | ✓ Certificate of calibration |
| ✓ Tempens software CD                     |                              |

## 2.2 Technical Specifications

Model	A250C+	A450C+
Temperature Range (Analog sub-range adjustable)	475°C - 1475°C	600°C - 1800°C 800°C - 2500°C
Spectral Range	1.5µm/1.6 µm	0.7....1.15 µm
Photodetector Type	InGaAs/InGaAs	Si/Si
Distance to Spot Size Ratio	150:1	150:1 ( 600°C - 1800°C) 300:1 (800°C - 2500°C)
Response Time	100 msec adjustable upto 10 sec	20 msec adjustable upto 10 sec
Emissivity (ε)	-	0.1....1.0 adjustable (Single color mode)
Emissivity Slope (ε1 / ε2)	0.75...1.25 slope adjustable (Two color mode)	
Accuracy	± 0.5% of the measured value + 1°C	
Repeatability	0.1% of reading in °C + 1°C	
Sighting Options	Laser Pilot Light(PL), Through The Lens (TL) & Video Module	
Analog Output	0-20mA, 4-20mA (User selectable)	
Digital Output	RS-485	
Operating Temp. Range	0°C.....70°C; 0°C.....200°C (With water cooling jacket)	
Storage Temp. Range	-20°C...70°C	
Adjustable Parameters and Features via Software and Android app	Emissivity, Emissivity Slope, Response Time, Clear Time (Peak Picker), Analog Output, Analog Scale (Sub range), Sensor type (Switches b\w 2-color or single color), Switch off level, Unit Of Temperature(°C/°F), Communication mode (Comm.mode), Record feature, Relay set point & hysteresis, etc.	
Adjustable Parameters and Features via Keypad	Emissivity, Emissivity Slope, Response Time, Clear Time (Peak Picker), Analog Output, Analog Scale (Sub range),Sensor type (Switches b\w 2-color or single color), Switch off level, Unit Of Temperature(°C/°F), Communication mode (Comm. mode), Relay set point & hysteresis, address, etc.	
Relay output	One Relay output with hysteresis 60V DC / 42 AC RMS, 0.4 A	
Power Supply	12V to 28V DC with reverse voltage protection	
Power Consumption	Max 2.5 watt	Max 4.0 watt
Laser Power	<1 m watt (only PL model)	
Protection Class	Ip65	
Housing	Stainless Steel	
Isolation	Power Supply, Digital Output and Analog Output are galvanically isolated against each other	
Operating Humidity	10-95%, Non-Condensing Conditions	
Weight & Dimensions	1200g Dia= Ø 56mm; Length=188.5mm	

### Dimensions

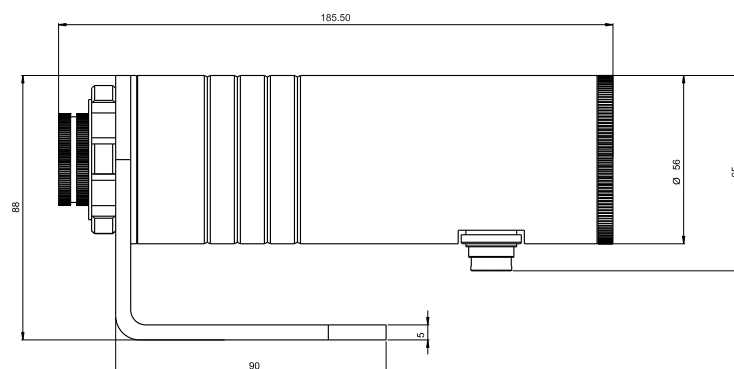


Fig. 1 Dimensions of Pyrometers

## 2.3 Optics

The pyrometer measure temperature by receiving heat radiation from the object whose temperature has to be measured. This heat radiation is passed through the lens sensor and then converted to an electrical signal. The farther the measured object from the pyrometer, the larger the area that will be measured.

**Table 1 :Some fixed optics focus is as below**

Focused working distances WD (mm)	Length L	Spot Sizes(mm)		
		A250C+ 475°C - 1475°C (150:1)	A450C+ 600°C - 1800°C (150:1)	A450C+ 800°C - 2500°C (300:1)
500	12.70	3.40	3.40	1.70
800	7.20	5.40	5.40	2.70
1000	5.50	6.70	6.70	3.40
2000	2.30	13.40	13.40	6.70
5000	0.50	33.40	33.40	16.70
9000	0	60.00	60.00	30.00

### Adjusting the required measuring distance:-

To achieve the spot sizes mention in the table above required measuring distance must be adjusted. This can be done between the smallest and the biggest limit value. For releasing the optics has to be turned anti clock wise. Then it can be pushed or pulled to find the correct measuring distance. For fixing the optics has to be turned clock wise.

### Adjusting the measuring distance with the help of the table:-

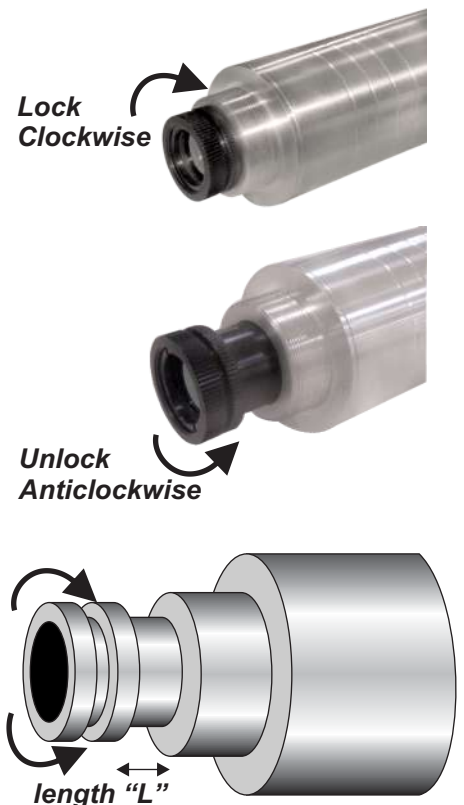
The table mentions the minimum and maximum measuring distance for each optics as well as several other values. The length "L" can be measured with a caliper. This length "L" can reach max. upto 14 mm.

### Adjusting the measuring distance with help of the thru lens view finder:-

The focusable optics is correctly adjusted to the required distance, if the measuring object is shown as a sharp image in the view finder. A circle marks the position of the measuring spot.

### Adjusting the measuring distance with help of the laser targeting light:-

On the focused measuring distance the laser has a smallest spot size.



**Fig. 2 Adjusting Measuring Distance**

---

# Chapter - 3

## Basics & Installation of the Pyrometer

### 3.1 Basics of Infrared temperature measurement of an object

Each and every object emit definite amount of infrared radiation and its intensity varies according to the temperature of object. Wavelength of infrared radiation lies approximately between 0.7 to 1000  $\mu\text{m}$  depending on the material and properties of object. Infrared radiations are sometimes also referred to as “heat radiations” depends mostly on the material. This material dependent constant value is known as “emissivity”, have a look at appendix B for emissivity values.

#### 3.1.1 Emissivity ( $\epsilon$ )

Emissivity is the ratio of energy radiated from an object to the exterior and energy radiated from blackbody. The emissivity varies with the surface condition of the object and also with temperature variation and wavelength. If this value is not accurate, then the true temperature cannot be measured. In other words a variation or change in emissivity will cause a change in the measurement.

If the value of emissivity low, your measured results may contain some errors due to interfering infrared radiations from objects which are behind the target object like heating systems, fireclay brick etc. Usually such type of problems occurs while measuring very thin materials like glass, plastic etc or some reflecting surface.

This error can be reduced if the sensor is shielded from reflecting radiation sources and also by properly, carefully installing the device.

By the application of Kirchhoff's law of thermal radiation “at thermal equilibrium, the emissivity of the body is equal to its absorptivity ( $\alpha$ )”. So for perfect black body,  $\epsilon$  is 1 while any real object would have  $\epsilon$  less than 1. Also the transmissivity ( $\tau$ ) and reflectivity ( $\rho$ ) is zero. The sum of absorptivity, reflectivity and transmissivity is always 1.

$$\alpha + \rho + \tau = 1$$

By emissivity factor materials can be categorized as

- ✓ Metals
- ✓ Non metals
- ✓ Transparent materials

#### 3.1.2 Calculation of emissivity of target object

There are various methods to do so but one of most prominently used is Calculate the actual temperature of target object using a RTD, Thermocouple etc. Measure the object's temperature by pyrometer and adjust emissivity settings in pyrometer unless correct temperature value is reached. Hence correct emissivity is measured of the target object.

### 3.2 Installation

#### 3.2.1 Mechanical installation of pyrometer

After all preparations are completed you can install pyrometer. Installation of pyrometer depends on the type of bracket you are using and the type of surface.

### 3.2.2 Distance of pyrometer from object

The desired spot size on the target will determine the maximum measurement distance and the focal length of the optical module. To avoid wrong readings the spot size of target must contain entire field view of the pyrometer. The pyrometer must be mounted so the entire field of view is the same or smaller than the desired target size. This is indicated in the below diagram.

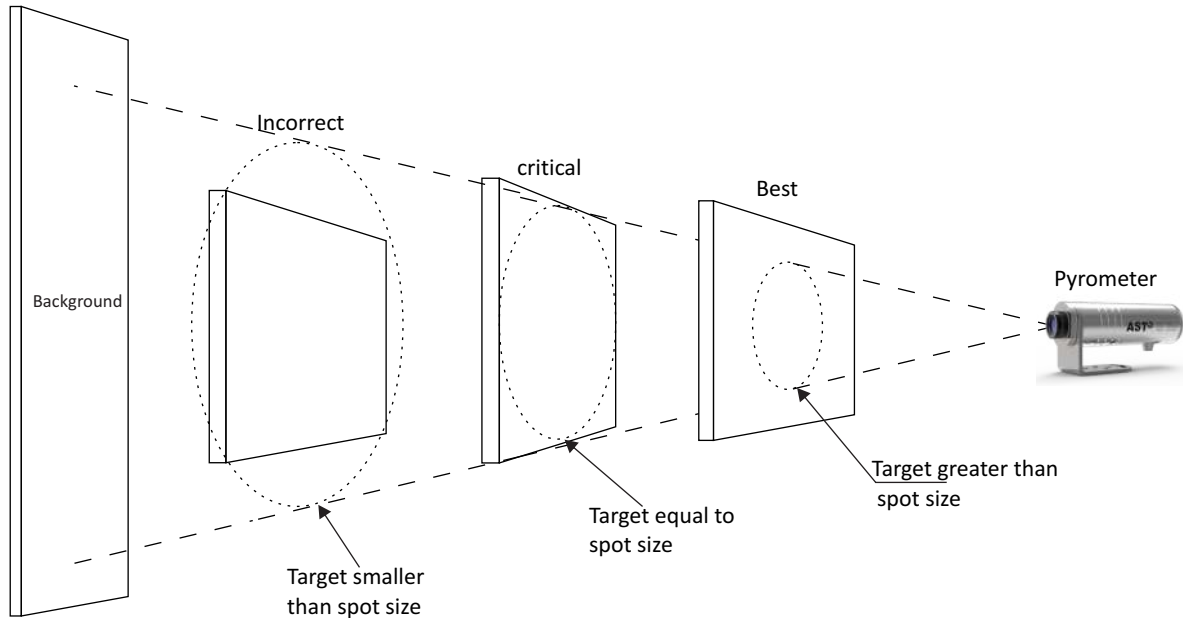


Fig.3 Proper mounting of pyrometer

### 3.2.3 Viewing Angles

The pyrometer can be placed at any angle from the target object up to 30°. indicated in the below diagram.

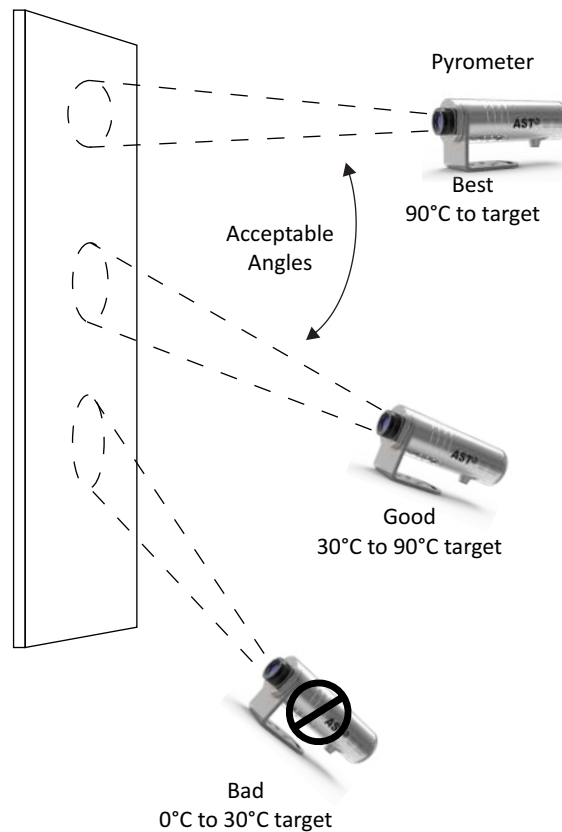


Fig. 4 Pyrometer Acceptable Viewing angles

---

### 3.3 Location selection

Qualified operating person should do the installation. Location should be good enough so that pyrometer should get continuous infrared radiation.

Pyrometer distance from object is according to below points:-

1. Pyrometer spot size should be small than object size.(read 3.2.2 & 3.2.3)
2. Know your pyrometer spot size according to point 2.3.
3. Pyrometer ambient temperature should be within 0° to 70°C (read 3.3.3).

#### 3.3.1 Correct Positioning of the pyrometer

*With pilot light (PL)*

A laser targeting light will help to correct the position of the pyrometer. It is recommended that laser should be switched off while measurement. It will increase the life of laser. To avoid measuring errors caused by a too big spot size the pyrometer must be fixed in the correct measuring distance, so that the object under measurement fills the spot size.

*With through the lens sighting (TL)*

In case of through the lens sighting a reticule circle marks the position of the measuring spot. This circle is true-sided and parallax-free.

**Note:** *The laser spot (PL) / reticule circle (TL) is only for indication of measuring spot, not exactly shows the measuring area.*

#### 3.3.2 Mounting of pyrometer

To install the pyrometer at the place of measurement a mounting support is supplied as an accessory, after losing the clamp screws, pyrometer can be mounted correctly in the mounting clamp.

#### 3.3.3 Ambient temperature

The allowed operation temperature for the pyrometer is 0°C to 70°C. Therefore if pyrometer is to be used above 70°C upto 200°C water cooling jacket with built in air purge unit is used otherwise it may damage the pyrometer. The ambient temperature is dependent on the temperature and flow rate of cooling water. Details of water cooling jacket& air purge are given in point 3.4.1.

#### 3.3.4 Atmospheric conditions

The pyrometer cannot receive the full infrared energy for the measurement if atmospheric conditions like smoke, dust or steam are present and hence it result in measuring error. An air purge unit can be helpful to avoid contamination such as dust and humidity on the lens. The air supplied should be at normal temperature with oil & moisture free. The air purge generates an air stream shaped like a cone and blows particles from the lens area.

### 3.4 Mechanical Accessories

#### 3.4.1 Water Cooling Jacket

This accessory is very important in order to use pyrometer at higher temperature. A normal pyrometer can withstand a temperature of 0-70°C. For higher temperature applications the device must be used with water cooling jacket upto 200°C.( for mechanical drawing refer Appendix C.)

- Water pressure : < 10 bar
- Air pressure : < 0.5 bar
- Air consumption : 2...3 m<sup>3</sup>/h
- Ambient temperature : < 200°C
- Metal : Stainless steel
- Weight : 3.0 Kg



**Fig. 5** Water Cooling Jacket  
(Reference no: 8500-09)

#### 3.4.2 Air Purge

This accessory is used to keep dust, moisture, airborne particle and vapours away from the lens head so that correct sighting of target object can be done. ( for mechanical drawing refer Appendix C.)

- Air pressure : < 0.5 bar
- Air consumption : 2...3 m<sup>3</sup>/h
- Metal : Aluminium
- Weight : 0.5 Kg
- Dry, clean air (Oil and dust free)



**Fig. 6** Air Purge Unit  
(Reference no: 8500-05)

#### 3.4.3 Adjustable mounting stand

This adjustable mounting stand will provide appropriate movement to the pyrometer. ( for mechanical drawing refer Appendix C.)

- Metal : Stainless Steel
- Weight : 0.9 Kg



**Fig. 7** Adjustable Mounting Stand  
(Reference no: 8000-07)

#### 3.4.4 Mounting Clamp

Mounting clamp can be used to hold the pyrometer.(for mechanical drawing refer Appendix C.) Fig. 8.

- Metal : Stainless Steel
- Weight : 0.45 Kg



**Fig. 8** Mounting Clamp  
(Reference no: 8500-04)

#### 3.4.5 Mounting Flange



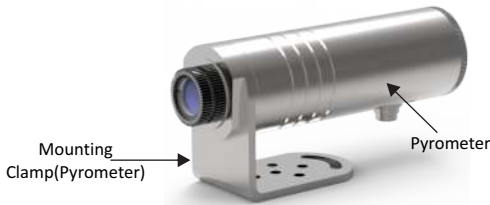
**Fig. 9** Mounting Flange  
(Reference no: 8500-07)

### 3.4.6 Mounting Plate

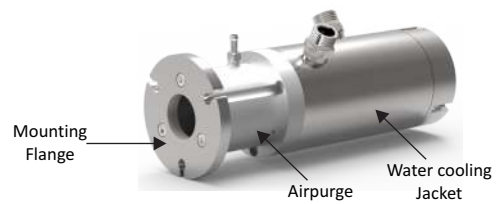


**Fig. 10** Mounting Plate  
(Reference no: 8500-08)

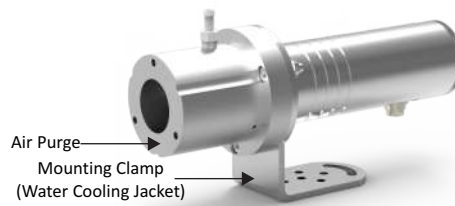
### 3.5 Combination of Accessories



**Fig. 11** Pyrometer with Mounting Clamp  
Reference No. (8500-04)



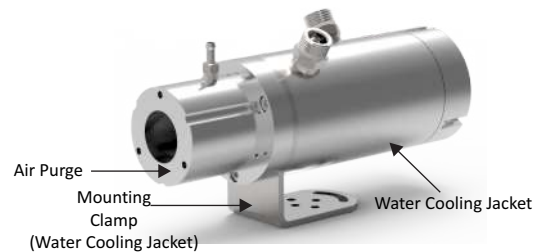
**Fig. 12** Pyrometer with  
Mounting Flange (8500-07) + Air Purge (8500-05)  
+ Water Cooling Jacket (8500-09)



**Fig. 13** Pyrometer with  
Air Purge (8500-05) + Mounting Clamp (8500-09)



**Fig. 14** Pyrometer with  
Mounting Flange (8500-07) + Air Purge (8500-05)



**Fig. 15** Pyrometer with  
Mounting Clamp (8500-06) + Air Purge (8500-05)  
+ Water Cooling Jacket (8500-09)

### 3.6 Electrical Installation

#### 3.6.1 Power Supply

24V DC (well stabilized ripple max 50mV).The input power supply is 110/230v AC. Check the polarity before connecting the device.

#### Device has following specifications

Power supply I/P : 100 - 240VAC, 0.35A  
50/60 Hz

Power supply O/P : +24V DC, 0.625A



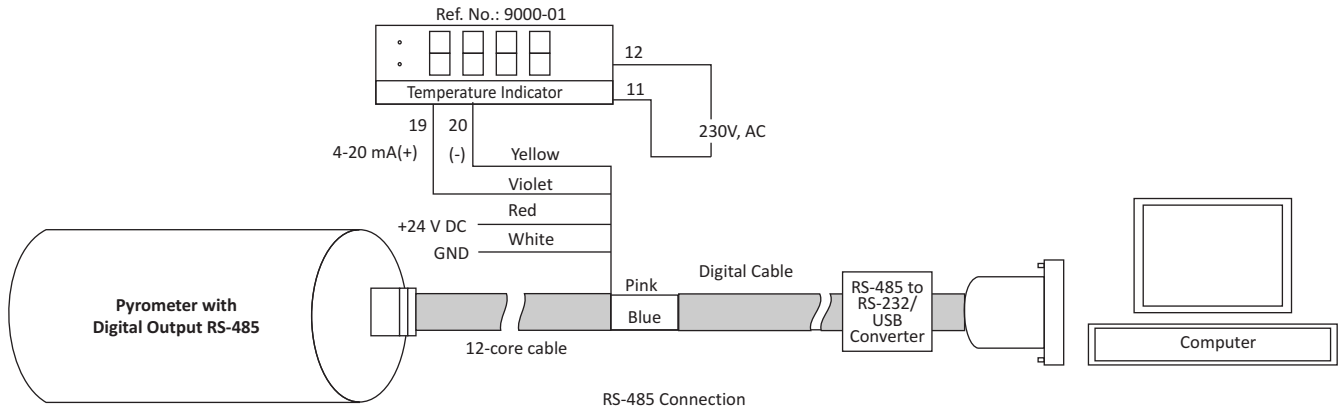
**Fig. 16** 12-Core Cable  
(Reference no: 7002-02)



**Fig. 17** Power Supply Unit  
(Reference no: 9000-02)

### 3.6.2 Connector pin assignment on the bottom of the pyrometer

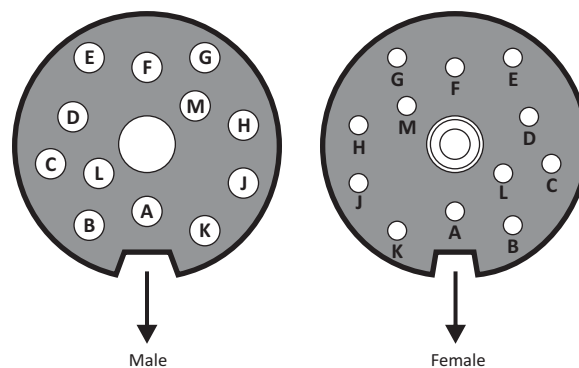
For connecting pyrometer with computer via connector pin (on the bottom of pyrometer) connection diagram is shown as under. Different colors and their indication is also shown in the table 2. So connections need to be done according to color, indication, used for particular purpose as in the table 2.



**Fig. 18** Connecting pyrometer (RS-485 Converted) with computer

**Table 2 :** Color code & Pin specification for pyrometer connections

Pin	Colour	Indication	Used for
A	Red	24 V DC	Power supply
G	White	Ground	
C	Blue	D- (RS-485)	RS-485 communication
D	Pink	D+ (RS-485)	
F	Black	RL1 NC	Relay Terminal
B	Grey	RL1-No	
H	Yellow	(-) 4-20mA / 0-20mA	Analog current output
M	Violet	(+) 4-20mA / 0-20mA	
J	Brown	Laser 2	Laser ON/OFF
K	Green	Laser 1	
E	Blue-Yellow	External Emissivity -mA	For External emissivity setting using 4...20mA
L	Red-Grey	External Emissivity +mA	



**Fig. 19** 12-pin Binder connector

- Note :**
- 1 Male - 12 pin binder connector is present on pyrometer side.
  2. Female - 12 pin binder connector is present on 12 core cable side.

### 3.6.3 Power ON Pyrometer

1. Connect the 12-core cable with 12-pin connector of pyrometer.
2. Connect supply wire with (Red, White) of 12 core cable with 24V DC power supply.
3. Connect remaining wires as per your requirement (details given in table above).
4. Provide insulation for not used end points of 12-core cable.
5. Now, the pyrometer can be switch ON.

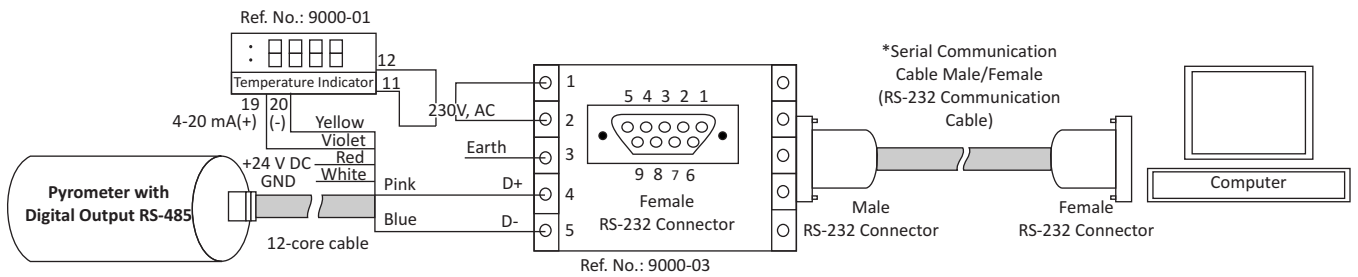
### 3.6.4 Converter RS-485 to RS-232



The pyrometer can communicate with PC using RS-485.

RS-485 is well suited for long distance transmission. Standard on PC is RS-232, so a converter is used which converts RS-485 to RS-232.

**Fig. 21** Converter RS-485 to RS-232  
(Reference no: 9000-03)



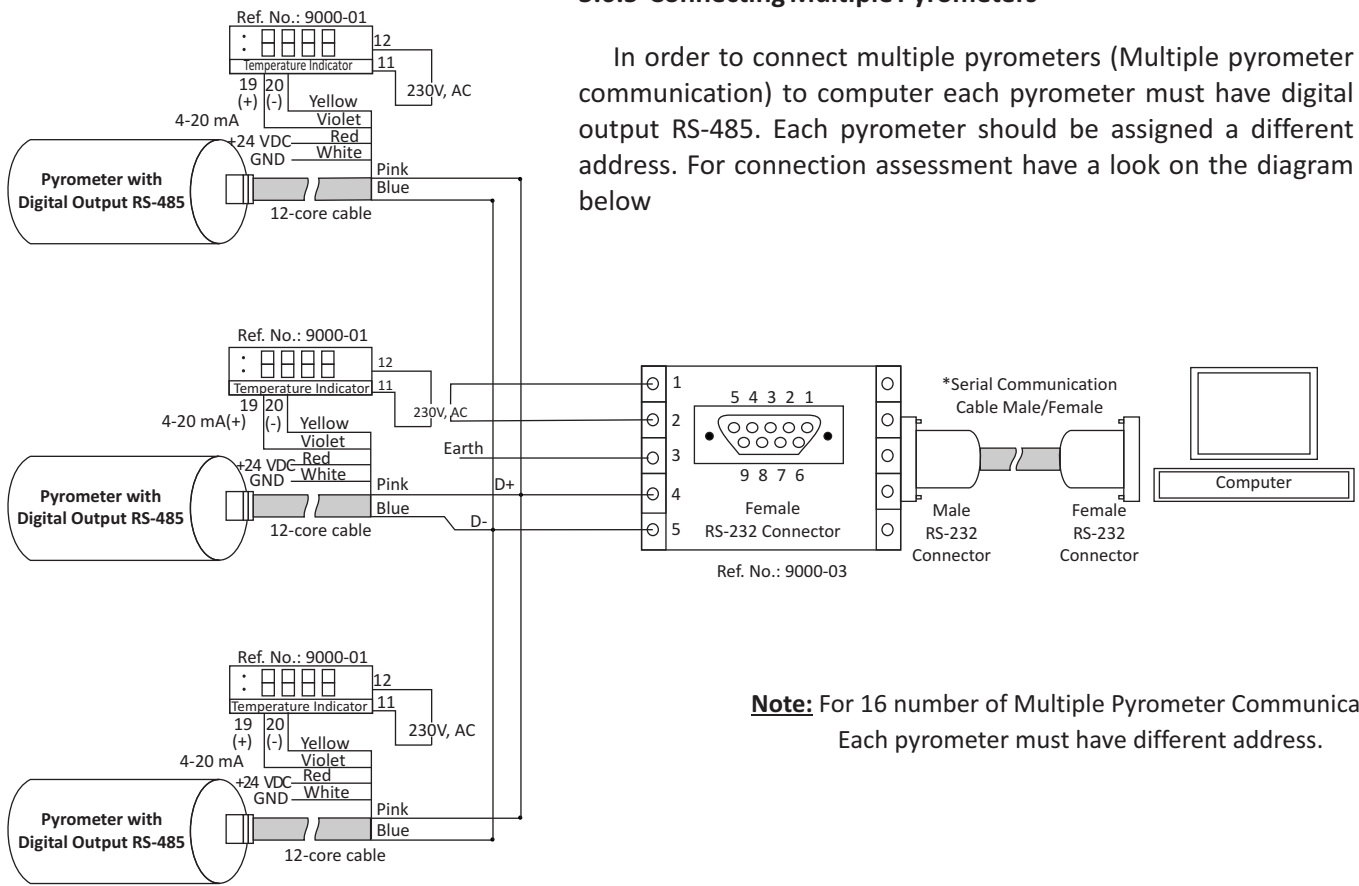
**Fig. 22** RS-485 to RS-232 Connection



**Fig. 23** Serial Communication Cable Male/Female  
(RS-232 Communication Cable)

### 3.6.5 Connecting Multiple Pyrometers

In order to connect multiple pyrometers (Multiple pyrometer communication) to computer each pyrometer must have digital output RS-485. Each pyrometer should be assigned a different address. For connection assessment have a look on the diagram below



**Note:** For 16 number of Multiple Pyrometer Communication, Each pyrometer must have different address.

Fig. 24 Multi-Pyrometer Connection

### 3.6.6 Display Instrument

To display the measured temperature 7 segment digital indicator is used. Display temperature according to 4...20mA analog output. Device has following specifications:

Power supply I/P	:	100 to 240 V, AC/DC
Analog I/P	:	4...20 mA
Retransmission	:	4...20 mA
Power supply O/P	:	24V, DC
Display	:	4 Digits
Alarm	:	2

### 3.6.7 Display & Parameterizer

P-120 is a high precision LED indicator for non contact temperature measurement. With indication of measured temperature user can easily parameterize a connected Tempsens digital pyrometer without any PC.

**Device has following specification:**

Power supply	:	100 – 240V, AC or 24V, DC
DC analog O/P	:	0-20 mA or 4-20 mA
Digital interface	:	RS-232 or RS-485
Pilot light	:	Pilot light On/Off with keys
Alarm with Hysteresis	:	2 Nos.



Fig. 25 Temperature Indicator  
(Reference no: 9000-01)



Fig. 26 Display & Parameterizer P-120  
(Reference no: 9001-01)

# Chapter - 4

## Setting at the instrument



Fig. 27 For PL Model

User can power up the unit by using connection cable at 24V DC input. After power up sensor starts an initializing routine for some seconds. After this the object temperature is shown in the OLED display.

**Note :** In TL model laser indication, Red LED and laser ON/OFF switch are not available

### 4.1 Operation

The programming keys FUNC, UP and DOWN enable the user to set the device on-site. Normally, OLED shows temperature or error. To view different parameter FUNC key is pressed repeatedly. To change values of parameters UP & DOWN keys are used. After changing values in any parameter by UP & DOWN key finally FUNC key should be pressed to save that value in device. If FUNC key is not pressed after changing parameter value than device will automatically take the old value & device will start showing temperature. If any key is not pressed for more than 5 sec. than device will automatically shows the temperature.

### 4.2 Key Description

**Up Key:**This key changes the options to the next available value in the upward order.

**Down Key :**This key changes the options to the next available value in the downward order.

**Enter/Function Key :**This key is used for various function selection.

**Status Indication(GreenLED):**under normal condition green LED glows continuously which indicates pyrometer is working correctly. If this LED blinks (getting ON & OFF) Indicates something is wrong which may be due to any of the following reasons

1. Target temperature is above the analog high range of pyrometer or target temperature is below the analog low range of pyrometer
2. Internal temperature is above ambient temperature high range of pyrometer(70°C) or internal temperature is below ambient temperature low range of pyrometer(0°C).

**Laser Indication :** When laser is ON (Red LED ON), Laser is OFF(Red LED OFF). User can operate laser by two methods:

**Method 1. :** By using green and brown wires

If Green and brown wires are short than red LED will glow which indicates laser is ON

If Green and brown wires are open than red LED will be OFF which indicates laser is OFF.

**Method 2. :** By using Laser ON/OFF key present on keypad.

User can also operate laser by using laser ON/OFF key but in this condition the green and brown wires should be open.

### 4.3 Adjustable Parameters

OLED Display	Parameters	Description
CM1	Single Color Mode	If user has selected <b>CM1</b> by pressing func. key & up down key for selection between CM1 & CM2, then pyrometer will work in <b>single color mode</b> .
EMI	Emissivity	By pressing function key emissivity will be shown. It is the relationship between the emissions of a real object and the emission of a black body radiation source at the same temperature. For a correct measurement it is necessary to adjust emissivity. Emissivity depends on the surface condition of the material, the spectral range of the pyrometer and the measuring temperature. Different material has different emissivity ranging from 0.1 to 1.0. user can change emissivity by up/down key on the instrument.
CM2	Two Color Mode	If user has selected <b>CM2</b> by pressing func. key and up down key for selection between CM1 & CM2, then pyrometer will work in <b>two color mode</b> .
ESR	Emissivity Slope	This parameter will be shown if two color mode (CM2) is selected, Different material has different Emissivity slope ranging from 0.75 to 1.25.
SP	Set Point	Instrument is equipped with a relay contact controlled by the measuring signal. The turn on temperature of relay is adjusted within the measuring range. The relay contact is "OPEN" below the adjusted value, it is "CLOSE" above it.
HST	Hysteresis (Hyst.)	The relay contact close when temperature exceeds the set point. It opens only if the temperature falls below a value which consists of set point and the adjusted hysteresis. It can be adjusted from 2° to 20°C. <b>Example</b> : if set point value is 900°C and Hysteresis set to 10. Then relay operation as below mentioned: <ol style="list-style-type: none"> <li>1. Relay contact OPEN below 910°C temperature.</li> <li>2. Relay contact CLOSE above 910°C temperature.</li> <li>3. Once relay contact CLOSED than relay contact is OPEN's when temperature falls below 890°C.</li> </ol>
ALO	Ana. Sub range Lo	Analog sub-range is adjustable within the basic range, user can set lower analog sub-range here.
AHI	Ana. Sub range HI	User can set the analog sub-range higher value here. Minimum span between lower & higher value is 51°C
AO	Analog Output	User can select the output from 4...20mA or 0...20mA
UT	Temp. Unit	User can select °C or °F unit.
ADD	Sensor Address	For communicating with pyrometer via software users have to give a address. The address may be 1 to 255.
TAU	Response Time	The response time can be set from 2 msec to 10sec.
SOL	Switch of Level	The switch of level is the function that is used to avoid measurement errors caused by signals, which are too low. Although factory default is set to 15 %, the switch off limit can be adjusted between 2 and 50%.

OLED Display	Parameters	Description
PIC	Peak Picker	<p>The peak picker can be switched ON &amp; OFF by using up down key. If the peak picker is switched on, the highest last temperature value will always be displayed and stored. This feature is particularly useful when object temperature is not uniform across its dimension or the pyrometer is not constantly viewing an object to be measured.</p> <p><b>Peak Picker Functions :</b></p> <p>When Peak picker is ON, the peak picker menu is enabled for setting of the parameters like decay rate function, reset below temperature and peak picker delay.</p>
DR	Decay Rate	<p><b>Decay rate</b> The Decay rate range is 0.00 to 166.66°C/sec. or 0.00 to 300°F/sec. depending upon °F/°C unit's selection. The slowest Decay rate is 0 degrees per sec. This feature helps to eliminate erratic measurements and allows the peaked value to decay down to lower process temperature values as they occur. Decay rate is set to retain peak measured temperature value and ignore momentary decreases in measured temperature.</p> <p style="text-align: center;"><b>Without Decay Rate</b>                      <b>With Decay Rate</b></p>
DT	Delay Time	<p>This function set the delay time in sec. before peak picker function starts. The delay time is selectable in the range 0.02 to 10.00 sec. Zero (0) turns delay time OFF. This function is used to delay the start of peaking action for upto 10 sec. following the detection of leading edge of a new target.</p> <p style="text-align: center;"><b>Delay Time (sec.)</b></p>
RBT	Reset Below Temperature	<p>The user can set RBT within the limit of pyrometer sub range. This function sets the temperature above which peak picker action starts. When the target temperature matches or is below the selected value, the sensor indicates temperature without picking action.</p> <p style="text-align: center;"><b>Without RBT</b>                      <b>RBT with Decay Rate</b></p>
IT	Internal Temperature	It shows the internal temperature of pyrometer.

**Note :** If any key is not pressed till 5sec. time duration the pyrometer will automatically comes out of match temperature function and start displaying target temperature.

#### 4.4 Special Function (Match Temperature)

<p style="text-align: center;"><b>MT</b></p>	<p><b>Match Temperature</b></p>	<p>This parameter is used to match the known target temperature value to be displayed by the pyrometer. After that below display will be shown.</p> <div style="text-align: center;"> <p>The diagram shows a rectangular display box. The top part contains the text '350.0 °C'. An arrow points from this text to the label 'Measured Temperature' on the left. The bottom part of the box contains the text 'MT : 350'. An arrow points from this text to the label 'Required Temperature' on the left.</p> </div> <p><b>Measured Temperature :</b> This indicates target temperature.</p> <p><b>Required Temperature :</b> User can change and set required temperature by UP/DOWN key press. Press Enter for confirmation. Now pyrometer measured temperature will automatically set to your required temperature.</p> <p><b>Meaning of Messages on OLED display :</b></p> <ol style="list-style-type: none"> <li>1. <math>\epsilon &gt; 1.0</math> : If calculated emissivity of required temperature is greater than 1.0 than emissivity will not change, save in pyrometer and also the measured temperature will not change.</li> <li>2. <math>\epsilon &lt; 0.1</math> : If calculated emissivity of required temperature is less than 0.1 than emissivity will not change, save in pyrometer and also the measured temperature will not change.</li> </ol> <div style="text-align: center;"> <p>The photograph shows a blue OLED display with two lines of text. The top line reads 'EMISS&lt;0.1' and the bottom line reads 'MT:587'.</p> </div> <p><b>Note 1 :</b> For MATCH TEMPERATURE parameter Peak picker should be OFF (PIC) if suppose it is found ON than below shown message will be displayed.</p> <div style="text-align: center;"> <p>A rectangular box with a black border containing the text 'NO WORK' on the top line and 'PICKER ON' on the bottom line.</p> </div> <p><b>Note 2 :</b> If any key is not pressed till 5sec. time duration the pyrometer will automatically comes out of match temperature function and start displaying target temperature.</p>
----------------------------------------------	---------------------------------	----------------------------------------------------------------------------------------------------------------------------------------------------------------------------------------------------------------------------------------------------------------------------------------------------------------------------------------------------------------------------------------------------------------------------------------------------------------------------------------------------------------------------------------------------------------------------------------------------------------------------------------------------------------------------------------------------------------------------------------------------------------------------------------------------------------------------------------------------------------------------------------------------------------------------------------------------------------------------------------------------------------------------------------------------------------------------------------------------------------------------------------------------------------------------------------------------------------------------------------------------------------------------------------------------------------------------------------------------------------------------------------------------------------------------------------------------------------------------------------------------------------------------------------------------------------------------------------------------------------------------------------------------------------------------------------------------------------------------------------------------------------------------------------------------------------------------------------------------------------------------------------------------------------------------------------------------------------------------------------------------------------------------------------------------------------------------------------------

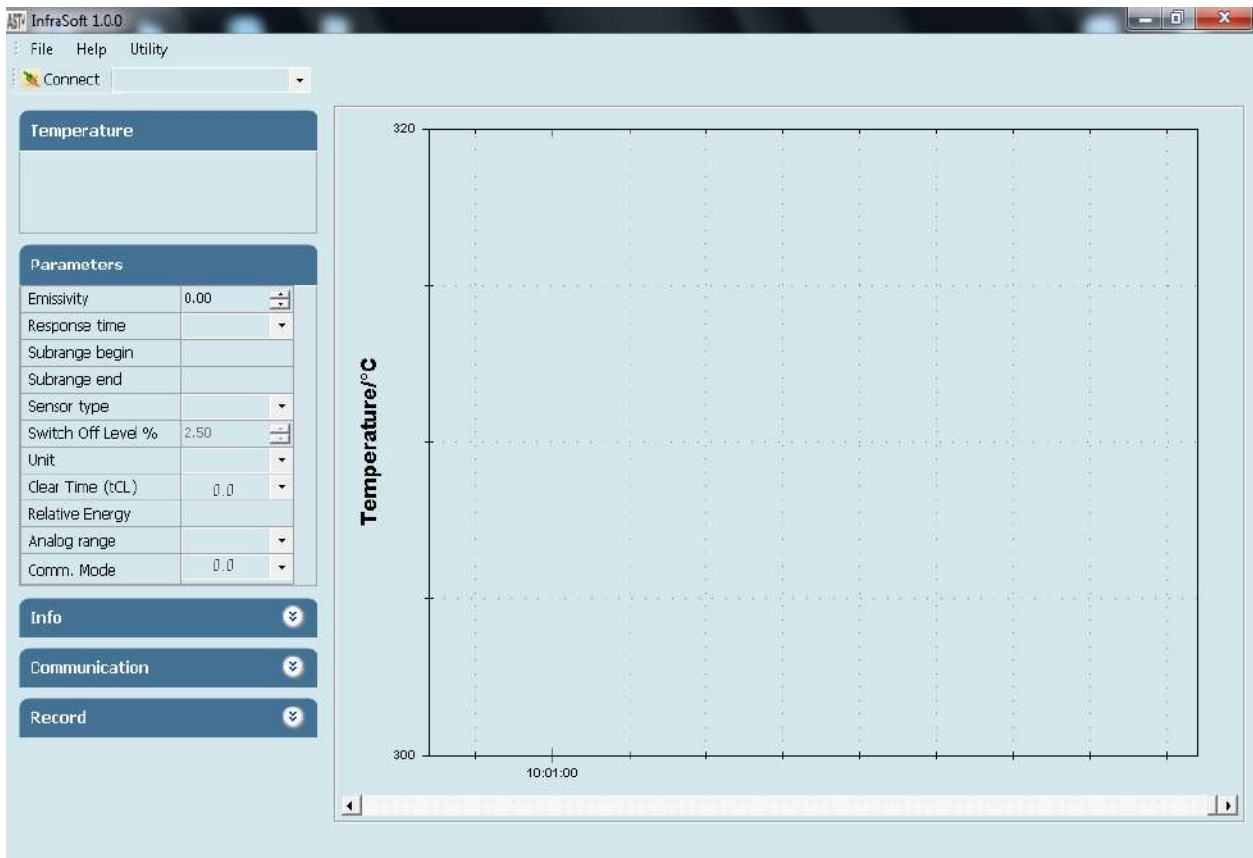
# Chapter - 5

## Software Installation

Tempsens infrasoft 1.0.1 provides facility to set all the parameters like response time, analog scale, emissivity, clear time, communication mode. This software provide all necessary information about pyrometer.

### 5.1 Installation

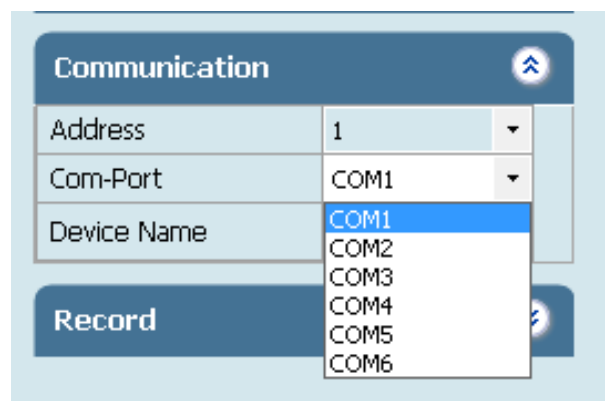
Install the pyrometer software using the installation guide file on CD ROM & restart your PC as per guidelines provided for installation. After installation of the software; Double click the application. It will open the screen of software.



### 5.2 Parameters in main screen

#### 5.2.1 Communication

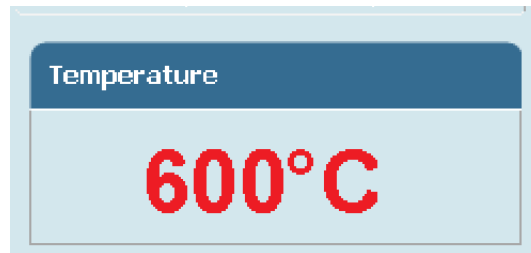
Communication between the Tempsens pyrometer and the software is implemented via a cable connected between the pyrometer and the PC serial port. This enables the acquisition and recording of data, as well as the transfer of commands from the software application to the Tempsens pyrometer. Communication can be done by clicking on "Communication panel" and select correct COM Port address where pyrometer is connected. Also user has to select address of the pyrometer(Example: Default 01/ printed on the pyrometer sticker). Then click on CONNECT Button.



For communication of multiple pyrometers, select different com port and address.

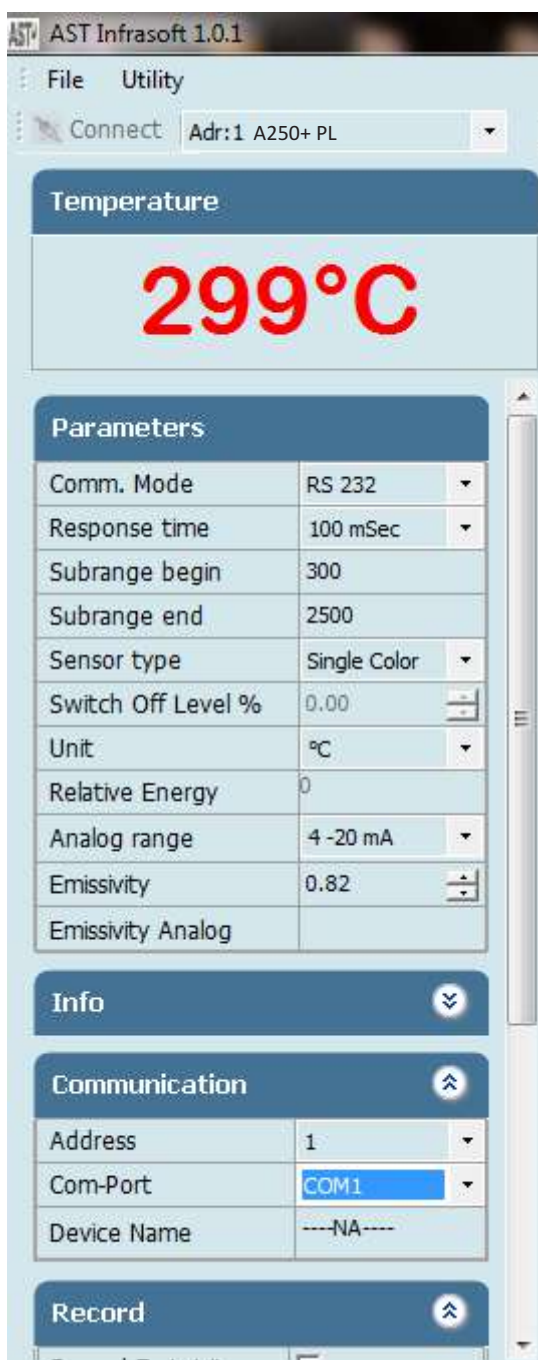
### 5.2.2 Temperature

It shows the temperature measured by the pyrometer



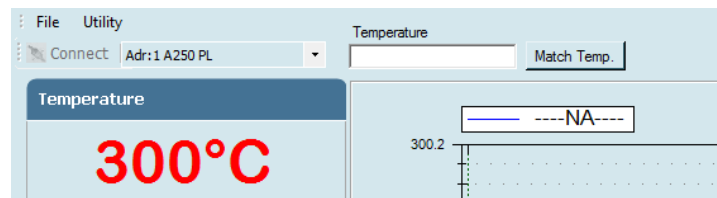
### 5.2.3 Parameter Setting

All user selectable device parameters can be set by using the software in the Panel "Parameter"



**(A) Emissivity settings** The emissivity can be set by clicking on "Parameters" and select or type in the desired emissivity directly in the description field. The emissivity value will be transferred to pyrometer by hitting the "TAB" button.

**(B) Match** This parameter is used to match the known target temperature value to be displayed by the pyrometer. The User can enter the required temperature in window provided. This value can be set by clicking on the "Match Temp." parameter in the software. The pyrometer automatically adjusts the emissivity so that the temperature display indicates the same temperature.



**(C) Response time** The desired response time can be chosen in the panel Parameter by clicking the appropriate list box (as per the values available in the drop box of response time). This parameter is use to set the analog response time of pyrometer.

**(D) Sub Range** User can change the sub range of pyrometer in the panel Parameter. Sub range must be within the basic range of pyrometer, the minimum span between higher & lower range is 51. Analog output will be automatically set according to the sub-range by hitting "TAB" button.

**(E) Sensor Type** It shows pyrometer sensor type. User can change sensor type from two color to single color and vice versa (only applicable with two color pyrometer).

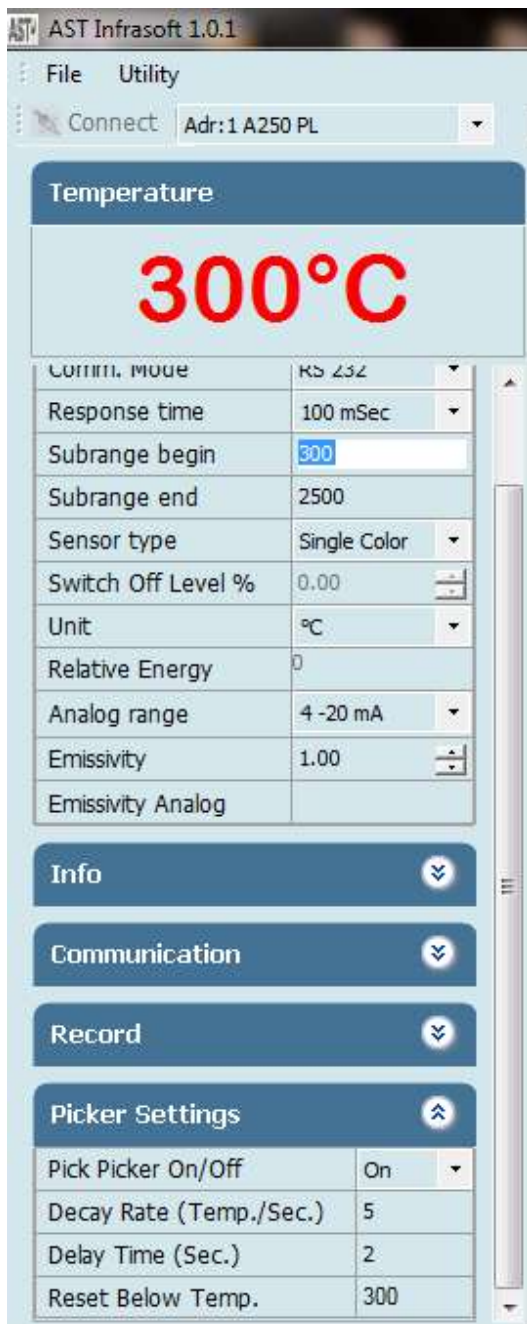
**(E)Switch off level% ( for two color pyrometer)** The switch of level is the function that is used to avoid measurement errors caused by signals, which are too low. Although factory default is set to 15 %, the switch off limit can be adjusted between 2 and 50%.

**(F)Unit** User can change the measuring unit of temperature from "Centigrade" to "Fahrenheit" and vice versa.

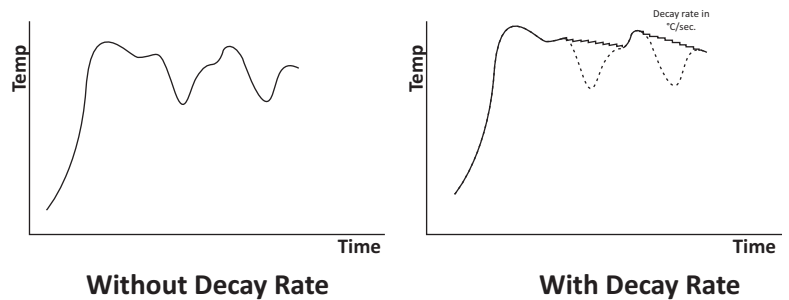
**(G)Peak Picker** If the peak picker is switched on, the highest last temperature value will always be displayed and stored. This feature is particularly useful when object temperature is not uniform across its dimension or the pyrometer is not constantly viewing an object to be measured.

**Peak Picker Functions :**

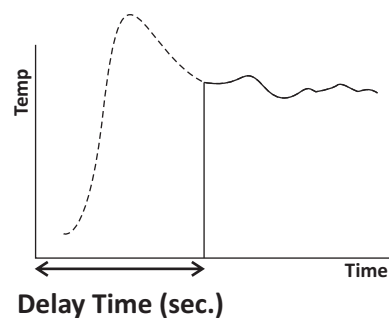
Peak picker can be turn ON & OFF by using the software. When Peak picker is ON, the peak picker menu is enabled for setting of the parameters like decay rate function, reset below temperature and peak picker delay.



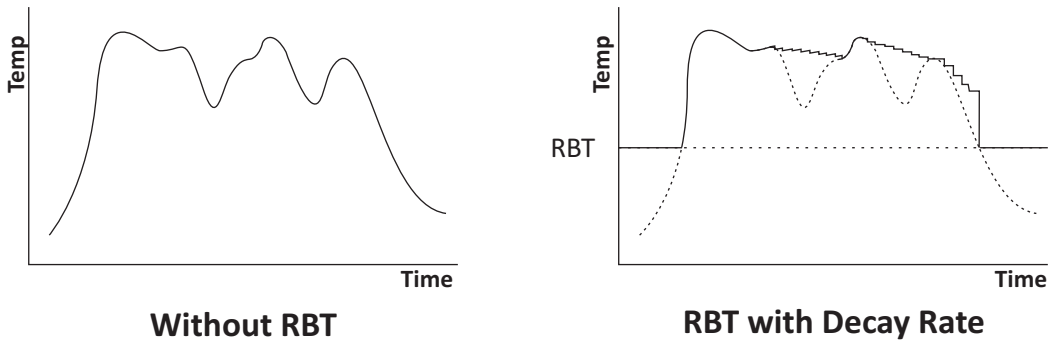
**(I)Decay rate** The Decay rate range is 0.00 to 166.66°C/sec. or 0.00 to 300°F/sec. depending upon °F/°C unit's selection. The slowest Decay rate is 0 degrees per sec. This feature helps to eliminate erratic measurements and allows the peaked value to decay down to lower process temperature values as they occur. Decay rate is set to retain peak measured temperature value and ignore momentary decreases in measured temperature.



**(II)Delay Time** This function set the delay time in sec. before peak picker function starts. The delay time is selectable in the range 0.02 to 10.00 sec. Zero (0) turns delay time OFF. This function is used to delay the start of peaking action for upto 10 sec. following the detection of leading edge of a new target.



**(III) Reset Below Temperature(RBT)** The user can set RBT within the limit of pyrometer sub range. This function sets the temperature above which peak picker action starts. When the target temperature matches or is below the selected value, the sensor indicates temperature without picking action.



**(H)Relative energy(for two color pyrometer)** The relative energy shows a signal weakening which can be caused by contaminations of the optics or a viewing window or by dust in the field of view or a too small measuring object. Relative energy shows the measured intensity compared to the intensity, a black body radiation source would have at a determined ratio temperature of the pyrometer.

**(I)Analog Range** User can select the analog range from the option 4-20mA, 0-20 mA & 0-10V.

**(J)Comm. Mode** User can select the communication mode as per requirement [RS-232 / RS-485].

**Note:** For connection diagram from RS-232 to RS-485 & RS-485 to RS-232 Refer Page No:-9

To view parameters of multiple devices select the pyrometer name from the drop down list that appears at the top of the screen.

### 5.2.4 Device information

Pyrometer specific information will be displayed in the Info Panel

This screen shows the Model, basic range, serial number, version, Head temperature, internal temperature, working distance, spot size-aperture.

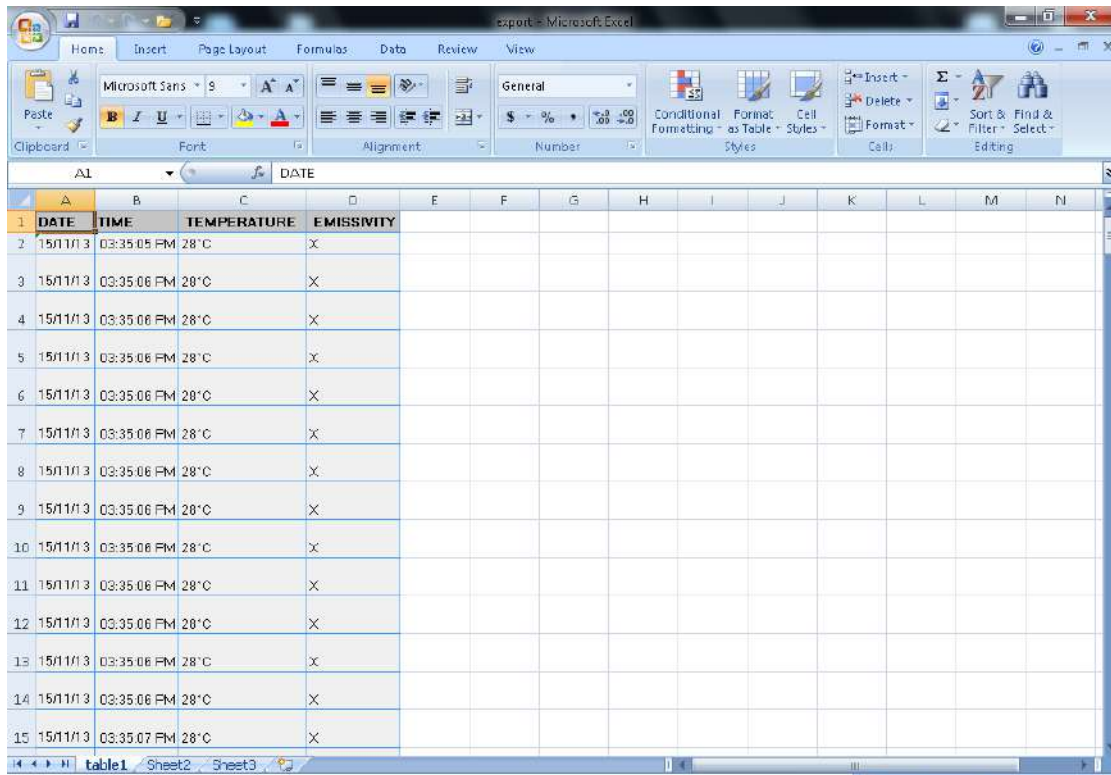
Info	
Model	AST A250 TL
Basic range	300°C ...1300°C
Serial number	849
FW Version	11.25
Head Temp.	0°C
Internal temp.	30°C
Working Dist. (mm)	300
Spot Size-Aprt. (mm)	2-5

### 5.2.5 Record

Record is for continuous data logging. It records the measured temperature, emissivity with current date & time. To start data logging click on start button. If user wants to record emissivity, click on record emissivity button. After Clicking Start button window appears where user can specify the file name & location.



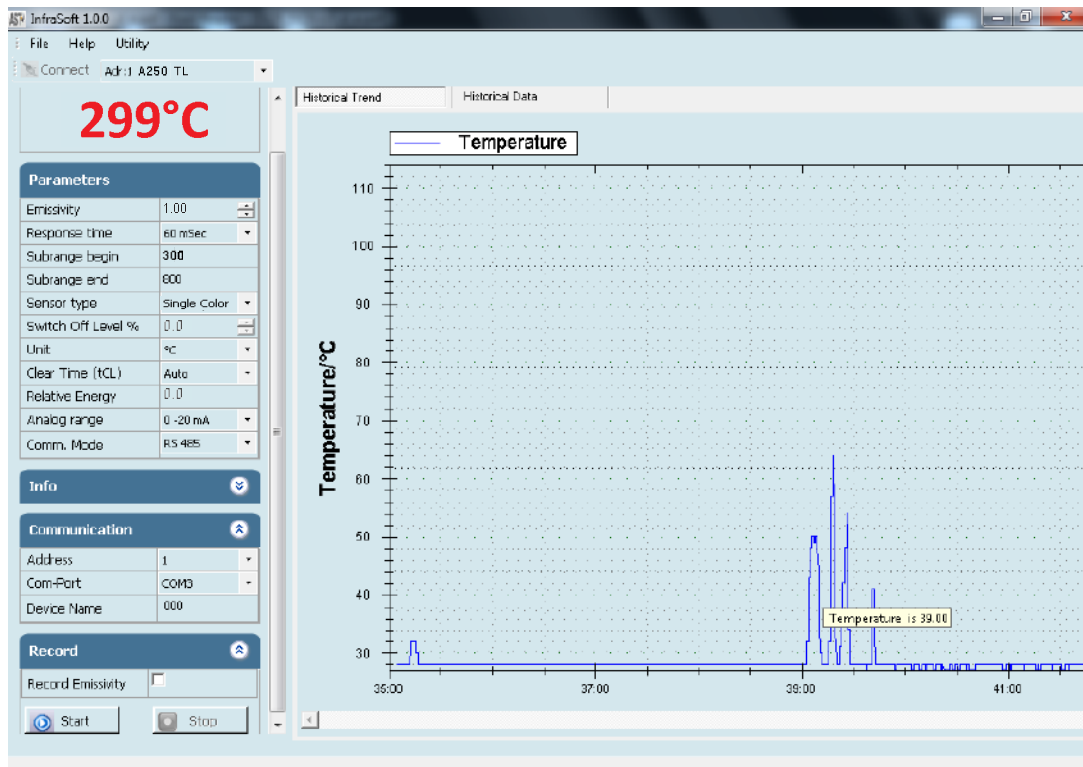
File will be stored in **.xls** format named as “export”. This “export.xls” file will be saved where the software is installed.

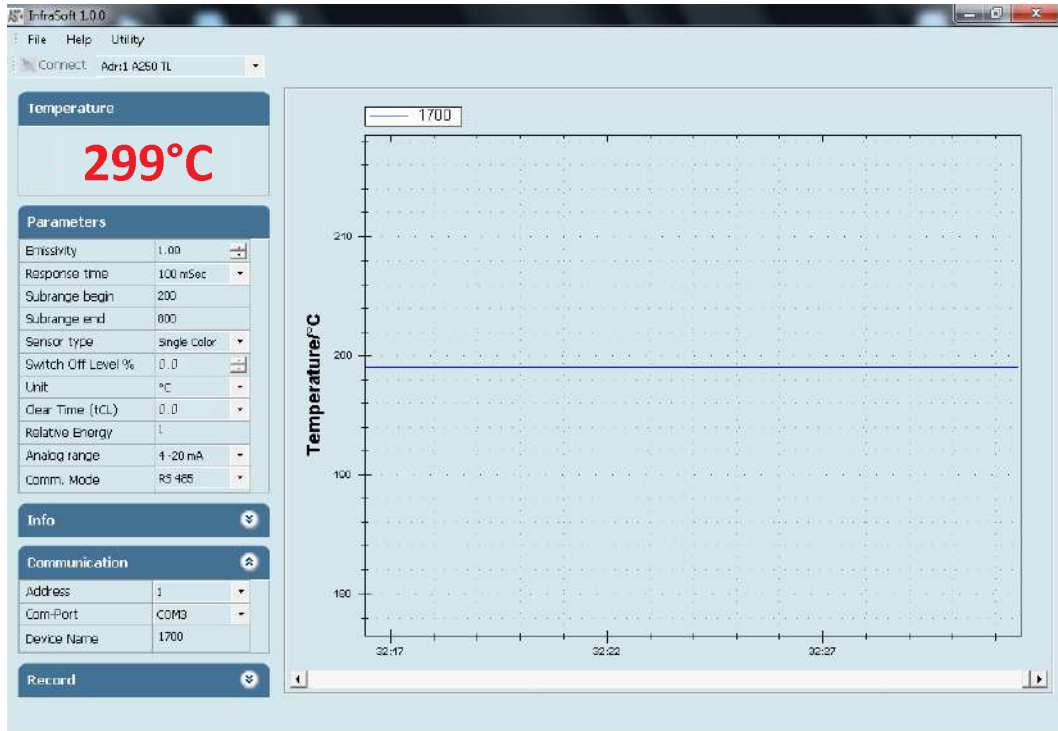


The screenshot shows a Microsoft Excel spreadsheet titled "export - Microsoft Excel". The spreadsheet has four columns: DATE, TIME, TEMPERATURE, and EMISSIVITY. The data is as follows:

	DATE	TIME	TEMPERATURE	EMISSIVITY
1	15/11/13	03:35:05 PM	28°C	X
2	15/11/13	03:35:06 PM	28°C	X
3	15/11/13	03:35:06 PM	28°C	X
4	15/11/13	03:35:06 PM	28°C	X
5	15/11/13	03:35:06 PM	28°C	X
6	15/11/13	03:35:06 PM	28°C	X
7	15/11/13	03:35:06 PM	28°C	X
8	15/11/13	03:35:06 PM	28°C	X
9	15/11/13	03:35:06 PM	28°C	X
10	15/11/13	03:35:06 PM	28°C	X
11	15/11/13	03:35:06 PM	28°C	X
12	15/11/13	03:35:06 PM	28°C	X
13	15/11/13	03:35:06 PM	28°C	X
14	15/11/13	03:35:06 PM	28°C	X
15	15/11/13	03:35:07 PM	28°C	X

To see previous record open the file by clicking on menu **File** → **open**.  
Screen containing historical trend & historical data will appear.

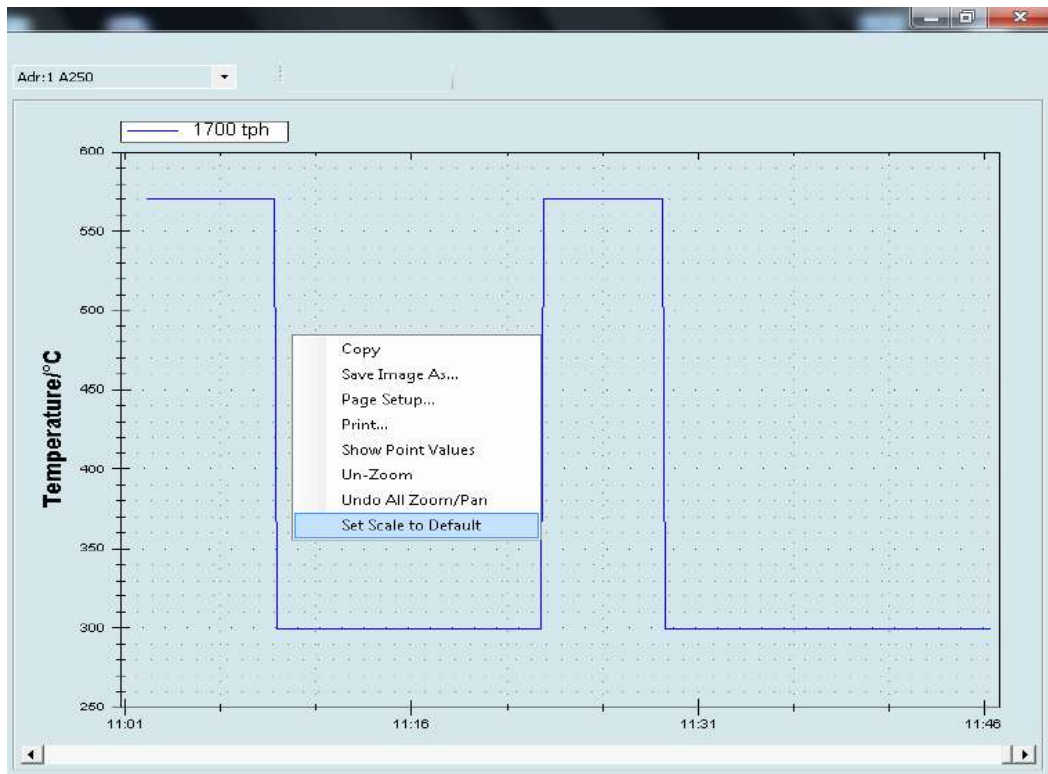




Temperature graph of connected pyrometer is displayed on right side of the screen. This shows the measured temperature corresponding to the time.

**Note:**

After connecting the pyrometer right click on the graph screen and choose "Set to default" option from pop-up menu.



---

# Chapter - 6

## Maintenance

In case of any queries, questions regarding repair, solutions to problems, calibration and assistance you may contact our sales representatives. Most of problems can be solved telephonically.

### 8.1 Cleaning Lens

The lens should be kept clean all the time as it aims at center of target object. When cleaning lens care should be taken and it can be done as follows :

- Firstly blow off lightly loose particles with “canned air” which is used for cleaning computer equipment or a small bellows squeeze (used for cleaning lenses).
- Now brush out gently remaining particles with a soft hair brush, a soft lens tissue can also be used.
- At last clean remaining particles “dirt” using a cotton or soft lens tissue dampened in distilled water. Do not scratch the surface.

In case of finger prints or any other grease material uses any of the following removing elements:

- Kodak lens cleaner
- Ethanol
- Denatured alcohol

Gently wipe with a soft, clean cloth after application of any of the above elements and wipe until you are able to see colours on the surface, then allow to air dry.

Do not wipe the surface dry, as this may result in scratches on the surface.

**Note:** Do not use any cleaners containing ammonia or simple ammonia to wash or clean the optical lens of pyrometer as this may permanently damage the surface of lens.

# Chapter - 7

## Serial communication protocol-MT500

This protocol is developed to use in the half duplex addressable communication mode. Master device should periodically issue requests to each Slave device. The request contains an address of polling “Slave” device. Slave device reply only on the requests issued by Master. Each Slave has its own address to recognize the issued request. Tempsens sensors always operate as Slave devices. Using RS485 serial communication option allows connecting more than one sensor to Master device. Tempsens sensors always perform delay of 5 ms before sending an answer on Master request to meet RS485 hardware requirement.

MT500\_Tempsens protocol uses only RD (Batch Read) and WD (Batch Write) commands. Sending other MT500 protocol commands causes sensor to consider it as error condition and answer with unknown command reply. Symbols enclosed within apostrophes ('symbol') means ASCII representation of the symbols. String enclosed with quotation mark ("string") means ASCII representation of the string (ended by '\0'). Data format is: 8 data bit, 1 stop bit, No parity, baud-rate 19200.

Description	Address	Items	Parameters
Emissivity	'0400'	'01'	Object emissivity multiplied by 1000. Refer user manual for adjustable range.
Emissivity slope	'0401'	'01'	Emissivity slope parameter multiplied by 1000. Refer user manual for adjustable range.
Response time ( $\tau$ )	'0105'	'01'	Parameter specifies analog and serial output response time. See Table 1.
Upper basic range	'0100'	'01'	Upper measurement range limit in °K (read only)
Lower basic range	'0101'	'01'	Lower measurement range limit in °K (read only)
Analog output type	'0F01'	'01'	'0000': 4 to 20 mA (Default); '0001': 0 to 20 mA, '0002': 0 to 10 Volt; '0003': K type TC; '0004': J type TC
Upper sub range	'0102'	'01'	Upper analog scale value in °K
Lower sub range	'0103'	'01'	Lower analog scale value in °K
Station number	'0200'	'01'	Adjustable between '0001' to '0255'
Temperature unit	'0201'	'01'	Flag is used to instruct PC SW to show temperature '0000': Centigrade (Default); '0001': Fahrenheit
Switch off level	'0107'	'01'	Parameter multiplied by 10. Adjusted between 0 and 100%, Default set to 15%.
Sensor mode	'0204'	'01'	'0000' = Single color; '0001' = Two color This parameter is useless for single color sensors.
Internal temperature	'0006'	'01'	Temperature inside device case in °C (read only)
Head temperature	'0007'	'01'	Temperature inside optical head m°C(only for E –series pyrometers) (read only)
Clear time(tCL)	'0303'	'01'	Adjustable between 0 to 12, Default 0, 0=OFF, 1=Auto. 2-12 = 10msec to 25sec [refer to page-13(clear time)]
Laser control	'0F00'	'01'	'0000': LASER OFF; '0001': LASER ON (Default)
Communication type selection	'0F03'	'01'	'0000':RS-485;; '0001': RS-232 (Default)
Set point	'1700'	'01'	Set point for relay actuation (only for E –series pyrometers)
Hysteresis	'1800'	'01'	Hysteresis value relay actuation
LCD back light control	'1801'	'01'	'0000': BL OFF; '0001': BL ON(Default) (Only for E-series pyrometers)
Device name	'1D00'	'01'	10 Bytes “Hot end ”, if less then 10 bytes pad with space at end.
Working distance (mm)	'1D01'	'01'	10 Bytes “1000 ”, if less then 10 bytes pad with space at end.
Spot size-aperture (mm)	'1D02'	'01'	10 Bytes “1000-6000” if less then 10 bytes pad with space at end. '.' sign between spot size and aperture is compulsory
Relative energy (read only)	'0002'	'01'	Relative energy multiply by 1000 for 2 color pyrometers only

Device model number (read only)	'0E00'	'01'	10 bytes "AST450C ", if less than 10 byte pad with space at end
Firmware version	'1300'	'01'	Firmware version number of device (read only)
Sensor serial number (read only)	'1400'	'01'	6 bytes in hex, if less than 6 bytes pad with '0' at start. Only numbers allowed.
Device type (read only)	'1301'	'01'	'0001': Single color; '0002' : Two color '0003': Thermopile; '0004' : Reserved
Real temperature and status code (read only)	'0000'	'02'	Calculated object temperature in °K and status of sensor (As shown in Appendix A). First process status code then real temperature.

### Batch Read (RD)command

Byte 1	Bytes 2,3	Bytes 4, 5	Bytes 6-9	Bytes 10, 11	Byte 12	Bytes 13, 14
1 Byte	2 Bytes	2 Bytes	4 Bytes	2 Bytes	1 Byte	2 Bytes
STX	Station ID	RD	Address	Items	ETX	Checksum

Byte 1: Always STX (0x02)

Bytes 2, 3: The Station Number of the device to read from (2 Hex digits)

Bytes 4, 5: The command to execute (RD)

Bytes 6-9: This is the starting address to read from. Must be 4 bytes long

Bytes 10, 11: This is the number of addresses (items) to read. Must be 2 bytes long

Byte 12: Always ETX (0x03)

Bytes 13, 14: The checksum is the lowest 8 bits of the sum of bytes 2 through 12

**Example :** Read two parameters starting from address 0000, from the station number 10 (0AH). This will read addresses 0000 and 0001.

Byte 1	Bytes 2, 3	Bytes 4, 5	Bytes 6-9	Bytes 10, 11	Byte 12	Byte 13, 14
STX	0A	RD	0000	02	ETX	2E
0x02	0x30, 0x41	0x52, 0x44	0x30,0x30,0x30,0x30	0x30, 0x32	0x03	0x32, 0x43,

Checksum is calculated as the lowest 8 bits of the sum of the Hex codes for bytes 2 to 12.

**Example :**  $70ARD\ 000002^1 + 0x30 + 0x41 + 0x52 + 0x44 + 0x30 + 0x30 + 0x30 + 0x30 + 0x30 + 0x32 + 3(ETX) = 22C \rightarrow$   
Checksum is 2C lower byte of the result.

### Reply

The reply length is  $L = (N * 4) + 8$ , Where N = the number of requested Items.

If the command is successful, the reply length will be at least 12 bytes. It consists of the STX, followed by four bytes for each requested item, then the ETX and Checksum.

Byte 1	Bytes 2, 3	Bytes 4, 5	Bytes 6-9	Bytes 10-13	Byte L-2	Byte L-1, L
STX	Station	RD	Data 1	Data N	ETX	Checksum

Reply to above command if address '0000' contains value 1497 and address '0001' contains value 0000.

Byte 1	Bytes 2, 3	Bytes 4, 5	Bytes 6-9	Bytes 10-13	Byte 14	Byte 15-16
STX	0A	RD	059D	0000	ETX	AC
0x02	0x30, 0x41	0x52, 0x44	0x30,0x35,0x39,0x44	0x30, 0x30, 0x30, 0x30	0x03	0x41, 0x43

in the event of an error, the reply is

Byte 1	Byte 2, 3	Byte 4, 5	Byte 6
NAK	0A	'R', 'D'	01 (Error Code)
0x15	0x30, 0x41	0x52, 0x44	0x30, 0x31

### Batch Write (WD) command

Byte 1	Bytes 2, 3	Bytes 4, 5	Bytes 6-9	Bytes 10, 11	Bytes 12-15	Bytes (L-6) - (L-3)	Byte L-2	Byte L-1, L
STX	Station ID	WD	Address	No. of Items	Data 1	Data N	ETX	Checksum

Byte 1	Bytes 2, 3	Bytes 4, 5	Bytes 6-9	Bytes 10, 11	Bytes 12-15	Byte 16	Byte 17,18
STX	0A	WD	0400	01	03E8	ETX	74
0x02	0x30, 0x41	0x57, 0x44	0x30, 0x34, 0x30, 0x30	0x30, 0x31, 0x30, 0x30	0x30, 0x33, 0x45, 0x38	0x03	0x37, 0x34

### Reply

If the command is successful, the reply is

Byte 1	Byte 2, 3	Byte 4, 5
ACK	0A	'W', 'D'
0x06	0x30, 0x41	0x57, 0x44

In the event of an error, the reply is

Byte 1	Byte 2, 3	Byte 4, 5	Byte 6
NAK	0A	'W', 'D'	01 (Error Code)
0x15	0x30, 0x41	0x57, 0x44	0x30, 0x31

## Error Codes

Error Code	Description	Comments
'1'	Invalid check sum	See how to calculate a check sum
'2'	Unknown command	Protocol uses only RD (Batch Read) and WD (Batch Write) commands
'3'	Data length error	Number of items in WD (Batch Write) command doesn't match number of data bytes
'4'	ETX not found	ETX (0x03) not present in command
'5'	Illegal Address	number of items in a request is set to 0; memory segment number in a request is out of 0-25; Wrong command value, No data at requested address;
'6'	More items requested	More than 99 items were requested in command
'7'	Unsuccessful write	It informs Master that it should repeat WD command

**Table 1**

Tau ( $\tau$ )	Analog Response Time, ms	Serial Response Time, ms
1	2	20
3	6	50
5	10	100
10	20	200
30	60	300
50	100	500
100	200	1000
300	600	2000
500	1000	3000
1000	2000	4000
3000	6000	5000
5000	10000	10000

# Appendix A

DATA	Comments
Status code	'0000' : No error '0001' : Signal is lower than sensor sensitivity '0002' : Out of range due to T brightness minimum '0003' : Too low energy '0004' : Signal is higher than sensor sensitivity '0006' : Sharp brightness jump '0007' : Non stable object measurement '0011' : Internal temperature warning '0013' : Thermopile ambient temperature too low '0014' : Thermopile ambient temperature too high '0015' : Pyrometer in testing mode '0016' : Pilot light ON '0017' : Measurement below lower basic range '0018' : Measurement exceeds upper basic range '0019' : Pyrometer in warm up period

## Broadcast Message

WD (Batch Write) command with Station ID of 0 is considered as broadcast message. Sensors process this command regardless of their Station Number and do not issue replies.

It is useful when master issues a request to change the same parameters of more than one Slave devices.

For more information write us at, [info@tempsens.com](mailto:info@tempsens.com)

# Appendix B

Typical emissivity values for various materials available:

All the emissivity values shown in the table are only approximate, as it depends various parameters and it may affect the emissivity of a material. These parameters are as under:

1. Temperature
2. Thickness of material
3. Angle of measurement
4. Spectral range of measurement
5. Geometry
6. Surface quality (polished, rough , oxidized, sandblasted)
7. Transmission

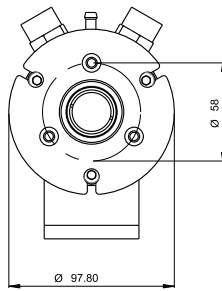
Material	Emissivity*
Aluminum, polished	0.05
Aluminum, rough surface	0.07
Aluminum, strongly oxidized	0.25
Asbestos board	0.96
Asbestos fabric	0.78
Asbestos paper	0.94
Asbestos slate	0.96
Brass, dull, tarnished	0.22
Brass, polished	0.03
Brick, common	0.85
Brick, glazed, rough	0.85
Brick, refractory, rough	0.94
Bronze, porous, rough	0.55
Bronze, polished	0.10
Carbon, purified	0.80
Cast iron, rough casting	0.81
Cast iron, polished	0.21
Charcoal, powdered	0.96
Chromium, polished	0.10
Clay, fired	0.91
Concrete	0.54
Copper, polished,	0.01
Copper, commercial burnished	0.07
Copper, oxidized	0.65
Copper, oxidized to black	0.88
Electrical tape, black plastic	0.95
Enamel **	0.90
Formica	0.93
Frozen soil	0.93
Glass	0.92
Glass, frosted	0.96
Gold, polished	0.02
Ice	0.97
Iron, hot rolled	0.77
Iron, oxidized	0.74
Iron, sheet galvanized, burnished	0.23
Iron, sheet, galvanized, oxidized	0.28
Iron, shiny, etched	0.16

Material	Emissivity*
Iron, wrought, polished	0.28
Lacquer, Bakelite	0.93
Lacquer, black, dull	0.97
Lacquer, black, shiny	0.87
Lacquer, white	0.87
Lampblack	0.96
Lead, gray	0.28
Lead, oxidized	0.63
Lead, red, powdered	0.93
Lead, shiny	0.08
Mercury, pure	0.10
Nickel, on cast iron	0.05
Nickel, pure polished	0.05
Paint, silver finish**	0.31
Paint, oil, average	0.94
Paper, black, shiny	0.90
Paper, black, dull	0.94
Paper, white	0.90
Platinum, pure, polished	0.08
Porcelain, glazed	0.92
Quartz	0.93
Rubber	0.93
Shellac, black, dull	0.91
Shellac, black, shiny	0.82
Snow	0.80
Steel, galvanized	0.28
Steel, oxidized strongly	0.88
Steel, rolled freshly	0.24
Steel, rough surface	0.96
Steel, rusty red	0.69
Steel, sheet, nickelplated	0.11
Steel, sheet, rolled	0.56
Tar paper	0.92
Tin, burnished	0.05
Tungsten	0.05
Water	0.98
Zinc, sheet	

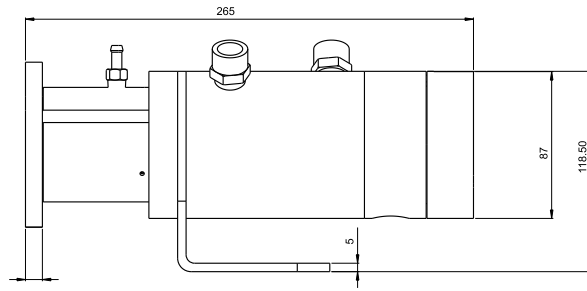
# Appendix C

## Mechanical Drawings

### 1. Water Cooling Jacket

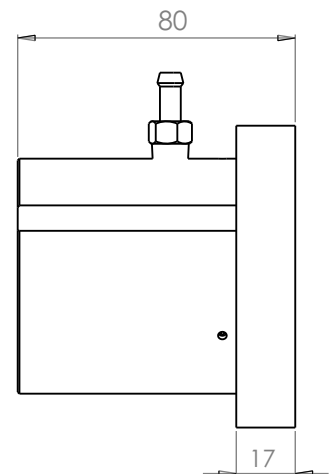
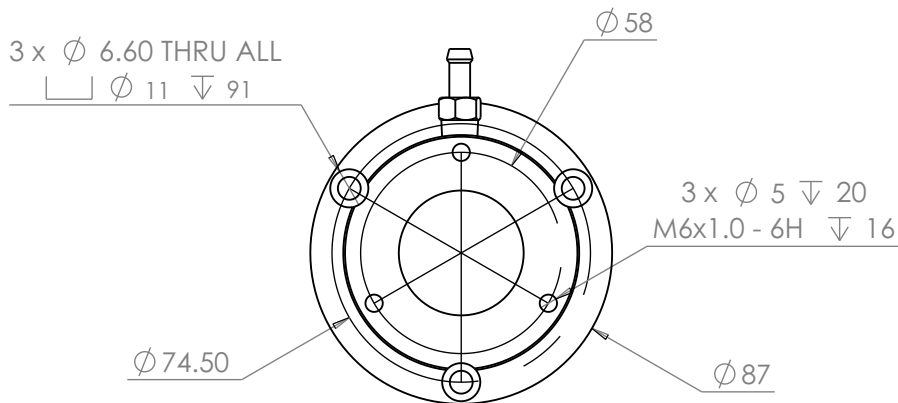


Water Cooling Jacket with Adjustable Flange PL  
(Reference no: 8000-02)



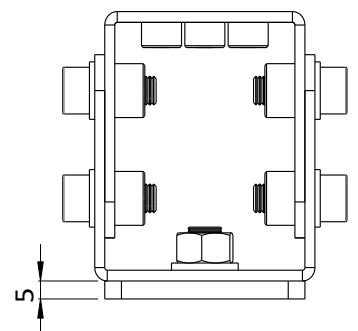
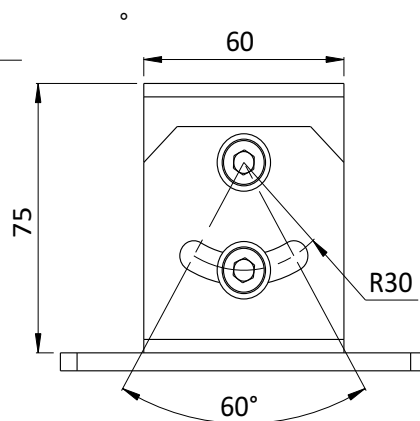
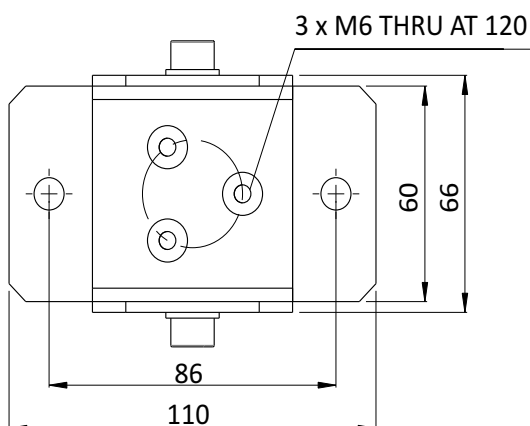
Water Cooling Jacket with Adjustable Flange TL  
(Reference no: 8000-06)

### 2. Air Purge Unit



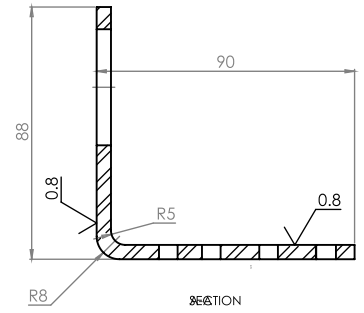
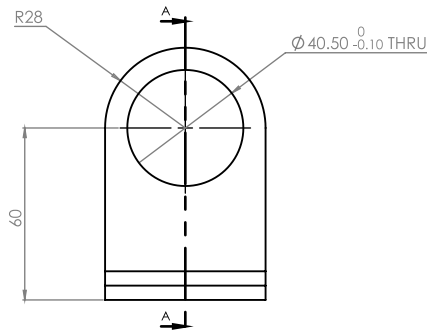
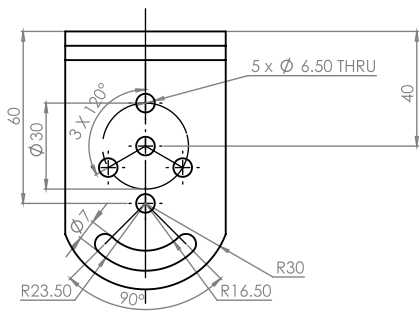
Air Purge Unit  
(Reference no: 8000-04)

### 3. Adjustable Mounting Stand



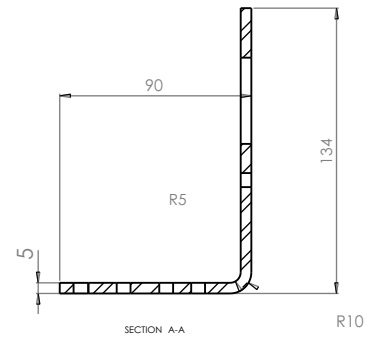
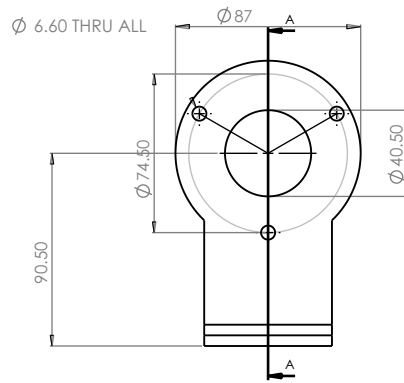
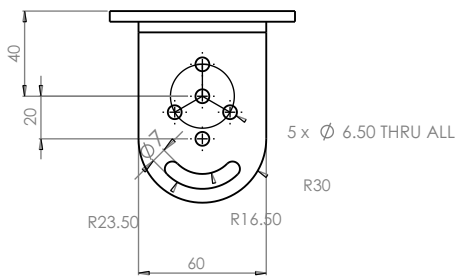
Adjustable Mounting Stand  
(Reference no: 8000-07)

### 3. Mounting Clamp (Pyrometer)



Mounting Clamp  
(Reference no: 8500-07)

### 4. Mounting Clamp Water Cooling Jacket



Mounting Clamp water cooling Jacket  
(Reference no: 8500-06)

---

# Information

## Maintenance

The pyrometer has no internal parts, which have to be cleaned. The lens can be cleaned with compressed air, which is dry and free of oil. If the protection glass requires more thorough cleaning, use a soft, dry cloth such as that used to clean camera lenses.

## Packing instructions

To transport or store the instrument, please use the original box or a box padded with sufficient shock absorbing material. For storage in humid areas or shipment overseas, the device should be placed in welded foil (ideally along with silicone gel) to protect it from humidity.

## Warranty

A250C+ PL/TL/VD/A450C+ PL/TL/VD instruments have a warranty of two years from the invoice date. This warranty covers manufacturing defects. User-induced faults are not covered under this warranty.

## Software warranty

The windows compatible software was thoroughly tested on a wide range of windows operating systems. Nevertheless, there is always a possibility that windows or PC configuration or some other unforeseen condition exists that would cause the software not to run smoothly. The manufacturer assumes no responsibility or liability and will not guarantee the performance of the software. Liability regarding any direct or indirect damage caused by this software is excluded.

## Limit of liability

Tempsens not liable for any damages that arise from the use of any examples or processes mentioned in this manual.

*Specifications are subject to change without notice*

---

Copyright: © 2009, AST. All rights reserved.

This document may contain proprietary information and shall be respected as a proprietary document to Tempsens with permission for review and usage given only to the rightful owner of the equipment with which this document is associated.

Tempsens reserves the right to make changes, without further notice, to any products herein to improve reliability, function, or design. Tempsens does not assume any liability arising out of the application or use of any product described herein, neither does it convey any license under its patent rights nor the rights of others.

Copyright: © 2009





# ABOUT US

## Tempsens Instruments (I) Pvt. Ltd.

Tempsens Instruments (I) Pvt. Ltd. is a part of Pyrotech Group which was established by four technocrats in 1976 at Udaipur, with their first product as Thermocouples and RTDs. Today 'Tempsens' is one of the largest manufacturers of Temperature Sensors in India.

Tempsens Instruments (I) Pvt. Ltd. U #II was started in 2009 to produce cables with high standard of manufacturing process conforming to national & international specifications. We manufacture wide range of cables for Temperature sensors and Instrumentation in various insulations as PTFE, FEP/PFA, Kapton, Silicon, Fiber Glass, Ceramic Fiber, Refrasil/Nextel, PVC etc. in variety of configurations. These cables are available in temperature range -60°C to 1200°C.

All our products are manufactured under strict ISO-9001 quality management system. We also provide Calibration Certificates with all cables. We stock most types of cables which enable us for fast delivery of goods. Our engineering staff are capable to custom design solutions for all applications for customers.

We are dedicated to provide the highest quality products that meet our customer's specifications for various applications.

We continuously focus on improving our manufacturing processes and competitiveness in the industry



[www.tempsens.com](http://www.tempsens.com)

**TEMPSSENS INSTRUMENTS (I) PVT. LTD.**

B-188A, Road No.5, Mewar Industrial Area (M. I. A.),  
Madri, Udaipur-313003 (Rajasthan) INDIA

**Ph.:+91-9116554600, Email: info@tempsens.com**