



## • A250 PL/TL • A450 PL/TL

210°C to 3000°C

### Features

- Wide temperature ranges from 210°C to 3000°C.
- Spectral Range 1.0 μm....1.6 μm
- Fast response time within milliseconds
- Analog output options available like 0...20mA, 4...20mA and 0...10V
- Laser or Through the Lens view finder sighting options
- Bluetooth V2.0 and RS-232/RS-485 Serial interface
- User friendly PC software for communication
- Small Spot Sizes
- Accessories for mounting and cooling options

### Standard Scope of Supply

- Pyrometer with Laser pilot light(PL)/Through the lens(TL) sighting(user can select while ordering)
- Analog output 4...20mA, 0..20mA, 0..10V
- Bluetooth V2.0
- Digital Interface RS-232 / RS-485(user selectable)
- 5 mtr long connection cable with connector
- 1.5 mtr. Communication Cable
- Calibration certificate, Software & Operation manual

### Optional

- Mechanical & Electrical Accessories
- Extra Cable Lengths
- Analog Emissivity variable 0.1 to 1.0 via continuous 4...20mA input (to be specified while ordering)

### Applications

- Induction Heating
- Casting
- Annealing
- Welding
- Forging
- Sintering
- Melting
- Rolling mills
- Hardening

## • A250 PL/TL • A450 PL/TL

Highly Accurate On-Line Infrared Non-Contact Pyrometer With Bluetooth V2.0



**A250 PL/TL** and **A450 PL/TL** are specially designed IR Pyrometers of A Series family for non contact temperature measurement in demanding industrial environments. The Pyrometers are highly accurate and compact by nature with stainless steel housing to provide high operational safety for harsh industrial environments. The Pyrometers are designed for high temperature applications between 210°C....3000°C.

The parameters like Emissivity, Analog Output, Sub Range, Response Time and Peak Picker etc can be preset ex-works or adjustable via Software. The Pyrometer provided with bluetooth V2.0 for communication between pyrometer & Android mobile, RS-232 & 485 for communication between pyrometer & PC software Infracsoft.

### Software “Infracsoft”

AST “Infracsoft “ software is under standard scope of supply. It offers possibilities of connecting three pyrometers simultaneously for parameter setting, view real time graph, offline graph and to evaluate measuring data. Communication between the pyrometer and the software is implemented via a cable connected between the pyrometer and the PC serial port. It comes with record feature, spot size calculator and parameter settings features. Some of the parameters adjustable via software are

- Emissivity, Response Time
- Clear Time(Peak Picker)
- Analog Output
- Sub Range
- Unit Of Temperature(°C/°F)
- Communication mode

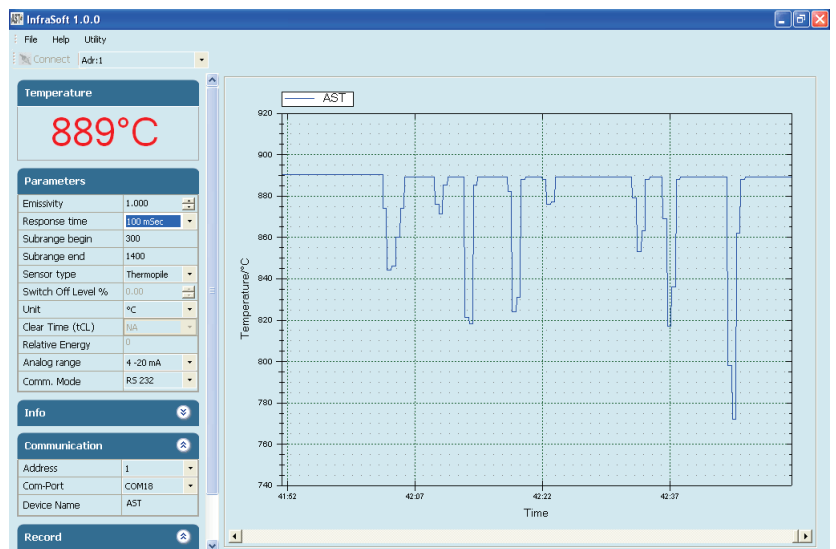

# AST Infrasoft

AST Infrasmart is an android application used to communicate a pyrometer with mobile devices. This application works via bluetooth after pairing with mobile. APK file for this android application will be provided with device.

Number of parameters set through the application are :

- Emissivity
- Response time
- Clear Time
- Unit of Temperature
- Analog Output
- Communication Mode
- Sensor Type
- Sub Range
- Data Logging

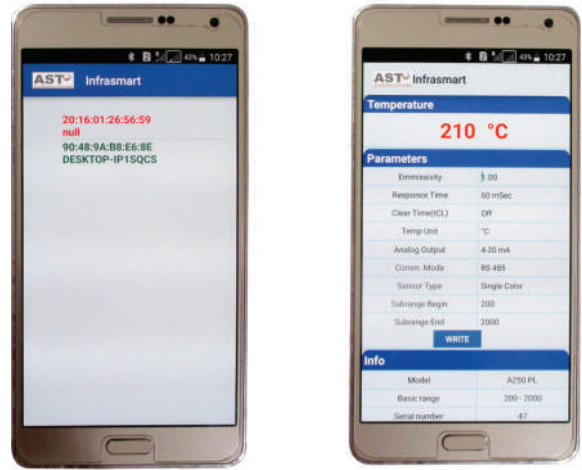

## Technical Specifications

Model	A250 PL/TL	A450 PL/TL
Temperature Range (Analog sub-range adjustable)	210°C....1350°C 250°C....1800°C 300°C....2500°C 350°C....3000°C	600°C....2500°C
Spectral Range	1.6 μm	1.0 μm
Photodetector Type	InGaAs	Si
Distance to Spot Size Ratio	50:1 (210°C....1350°C) 100:1 (250°C....1800°C) 200:1 (300°C....2500°C) 200:1 (350°C....3000°C)	200:1 (600°C....2500°C)
Emissivity (ε)	0.1....1.0 adjustable	
Response Time	2 msec adjustable upto 10 sec	
Accuracy	± 0.3% of the measured value + 1°C	
Repeatability	0.1% of reading in °C + 1°C	
Sighting Options	Laser Pilot Light (PL) / Through The Lens (TL)	
Analog Output	0-20mA, 4-20mA, 0-10V (User selectable)	
Digital Output	Bluetooth V2.0 RS-232/RS-485 (User selectable) *At a time only one digital output possible	
Operating Temp. Range	0°C.....70°C 0°C.....200°C (With water cooling jacket)	
Storage Temp. Range	-20°C...70°C	
Adjustable Parameters and Features via Software	Emissivity, Response Time, Clear Time(Peak Picker), Analog Output, Analog Scale (Sub Range), Unit Of Temperature(°C/°F), Communication mode (Comm. mode), Record feature etc	
Power Supply	12V to 28V DC with reverse polarity protection	
Power Consumption	Max 2.5 watt	
Laser Power	<1 m watt	
Protection Class	IP65	
Housing	Stainless Steel	
Isolation	Power supply, Digital output and Analog output are galvanically isolated against each other	
Operating Humidity	10-95%, Non-Condensing Conditions	
Weight & Dimensions	600g, Dia= Ø 49.5 mm; Length=118mm	

## Spot Sizes

Manufactured working distances WD (mm)	Spot Sizes(mm)			
	A250 210°C - 1350°C (50:1)	A250 250°C - 1800°C (100:1)	A250 300°C - 2500°C 350°C - 3000°C (200:1)	A450 600°C - 2500°C (200:1)
350	7	3.5	1.75	1.75
500	10	5	2.5	2.5
700	14	7	3.5	3.5
800	16	8	4	4
1000	20	10	5	5
1500	30	15	7.5	7.5
2000	30	20	10	10
2500	50	25	12.5	12.5
3000	60	30	15	15
5000	100	50	25	25
Aperture(A)	11	11	11 (300 - 2500°C) 4 (350 - 3000°C)	12(600 - 2500°C)

## Accessories

Water Cooling Jacket  
(Reference no: 8000-08)



Adjustable Mounting Stand  
(Reference no: 8000-07)



Air Purge Unit  
(Reference no: 8000-04)



Adjustable Mounting Support  
(Reference no: 8000-05)



Display & Parameterizer P-120  
(Reference no: 9001-01)



Converter RS-232 ↔ RS-485  
(Reference no: 9000-03)



Power supply Input 110/230V AC  
Reference No. 9000 - 02  
Output 24 V DC, 0.7Amp.



Temperature Indicator  
(Reference no: 9000-01)



# Pyrometer Drawing

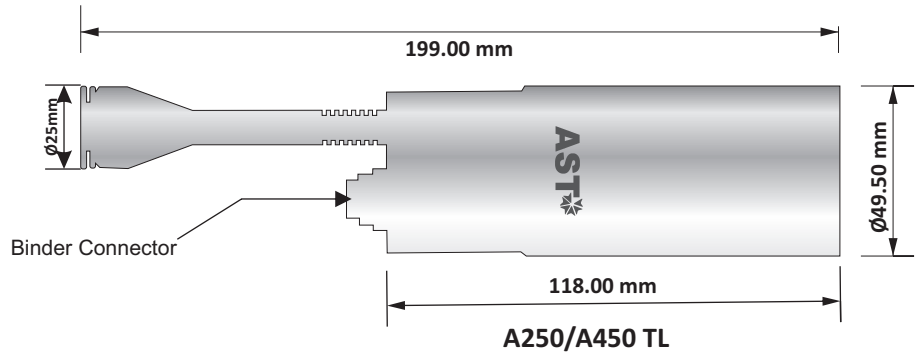
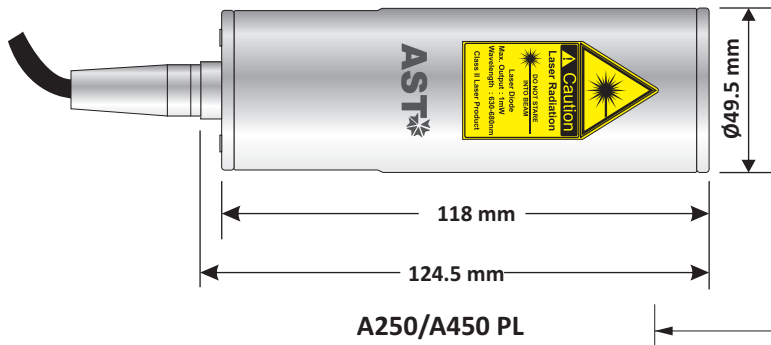

# Pyrometer Accessories Drawings

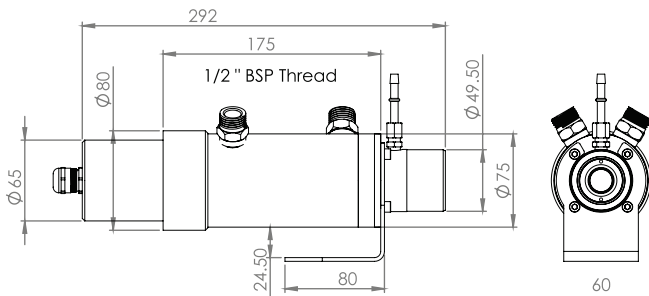

**Water Cooling Jacket**  
(Reference no: 8000-08)

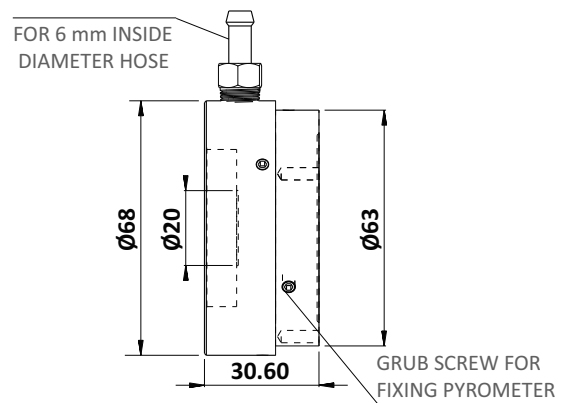

**Air Purge Unit**  
(Reference no: 8000-04)

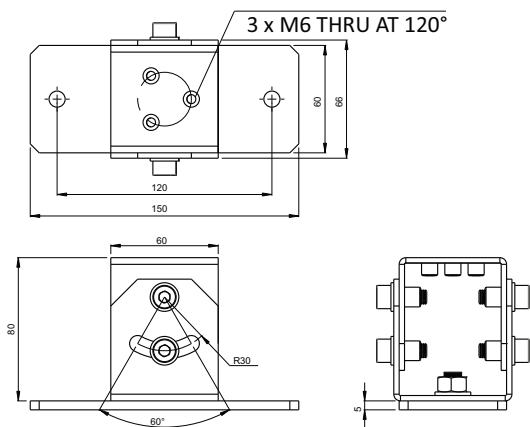

**Adjustable Mounting Stand**  
(Reference no: 8000-07)

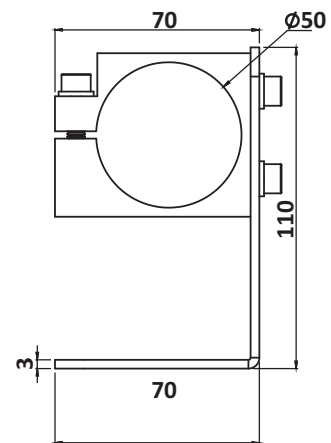

**Mounting Clamp**  
(Reference no: 8000-05)