

THERMOCOUPLES FOR DISTRIBUTOR AND FORE HEARTH

In distributor and fore hearths temperature measurement and control is most important. The glass fore-hearth control system includes a temperature sensing system and control system. The temperature sensing system includes an arrangement of pre-positioned temperature sensors. Simplex thimble thermocouples and tri-level / triplex thermocouples consist of an assembly of a bottom, middle and top thermocouples for sensing the vertical temperature profile of the molten glass at a fixed location. The output signals from these temperature sensors are received by controllers of the control system which then provide control signals and regulate the operation of the heat input devices and the cooling input devices. Thermocouple output and controller's calibration must be accurate, reliable and repeatable.

The Tri-Level Thermocouples designed to achieve thermal homogeneity of the glass exiting from the fore-hearth for forming, as the homogeneity will help to get the proper distribution of Gob in moulds.

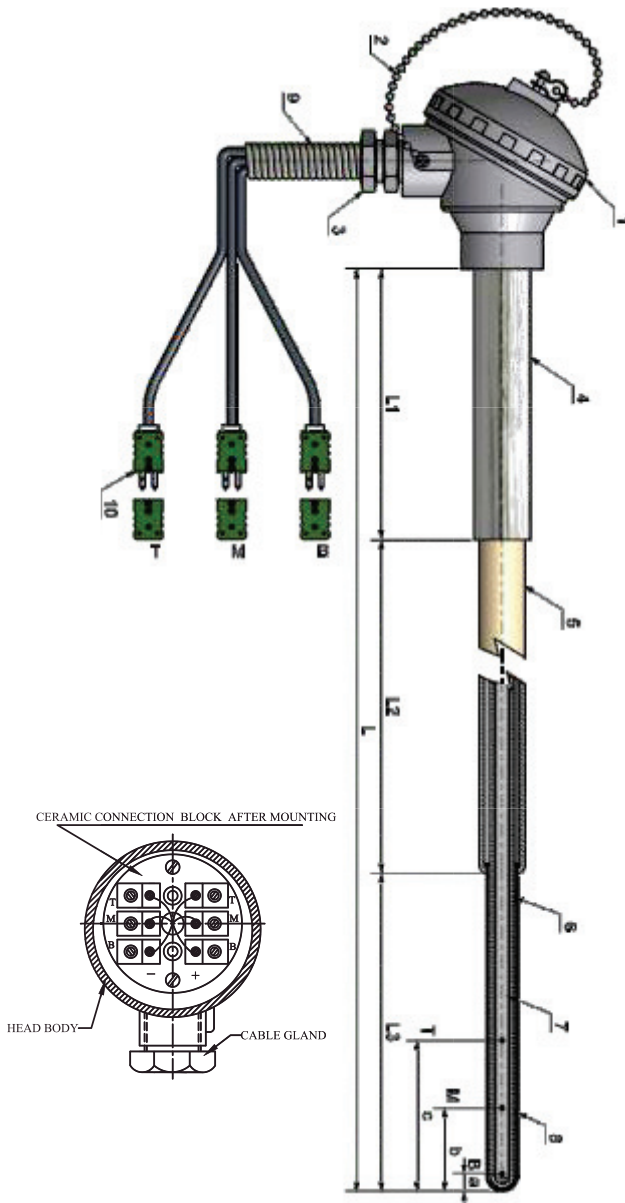
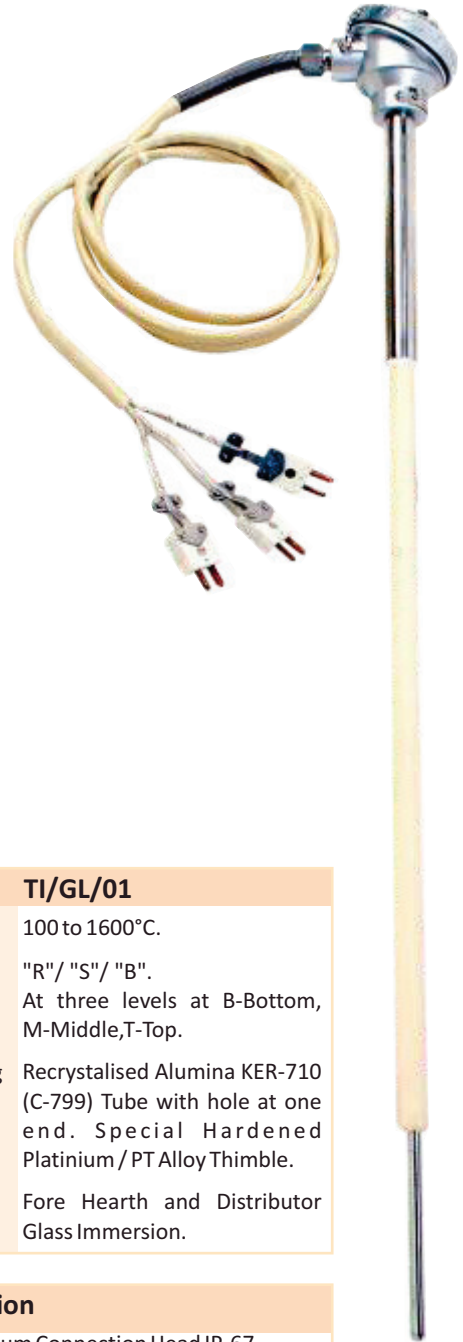

TI / GL / 01

Type	TI/GL/01
Measuring Range	100 to 1600°C.
Sensor Type	"R"/ "S"/ "B". At three levels at B-Bottom, M-Middle, T-Top.
Protection Sheathing	Recrystallised Alumina KER-710 (C-799) Tube with hole at one end. Special Hardened Platinum /PT Alloy Thimble.
Application	Fore Hearth and Distributor Glass Immersion.

S.No.	Description
1.	SS/Aluminium Connection Head IP-67.
2.	SS Chain.
3.	½" NPT(M) Cable Gland.
4.	Holding Tube : (Inconel - 600/SS310).
5.	Recry. Alumina Tube :- OD X ID to be specified.
6.	Inner Tube suitable to Outer Tube.
7.	6 Bore Recry. Alumina Insulating Tube.
8.	Hardened PT/PT Alloy Thimble :- OD X THK. suitable to Outer Dimension.
9.	Ceramic Fibre Insulated Compensating Cable 3/6 Mtrs. long with overall ceramic fiber sleeve.
10.	Quick Release Compensated Connectors "R"/ "S"/ "B" Type.
■	a,b,c are distances from tip to bottom, middle & top sensor elements depending on the design.

THERMOCOUPLES FOR DISTRIBUTOR AND FORE HEARTH



In TI/GL/01 uses small thimble length. That model is economic and commonly used worldwide, normally it gives very good service life but the only disadvantage is recovery of platinum as the ceramic tube is in flame contact and if it breaks, one can loose the whole thimble. In TI/GL/02 thimble length is long, it is from glass immersion to roofing block and thimble shall be in flame, there is no joint of ceramic tube & PT thimble in fore hearth atmosphere. It is quite popular design in heavy draw fore hearths. Where glass draw is high, customer can choose as per their requirement. All thermocouples are custom built.

Type	TI/GL/02
Measuring Range	100 to 1600°C.
Sensor Type	"R"/ "S"/ "B". At three levels at B-Bottom, M-Middle, T-Top.
Protection Sheathing	Special Hardened Platinum / PT Alloy Thimble.
Application	Fore Hearth and Distributor Glass Immersion.

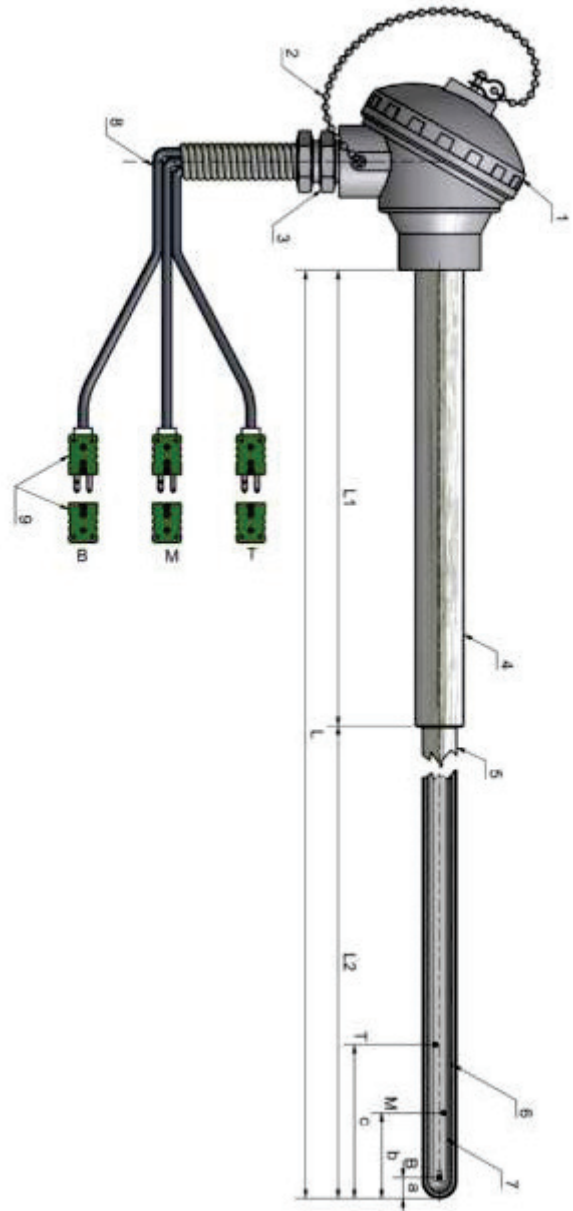

S.No.	Description
1.	SS/Aluminium Connection Head IP-67.
2.	SS Chain.
3.	½" NPT(M) Cable Gland.
4.	Holding Tube : (Inconel - 600/SS310).
5.	Hardened PT/PT Alloy Thimble :- OD X THK. suitable to Inner Dimension.
6.	Recry. Alumina Tube :- OD X ID to be specified.
7.	6 Bore Recry. Alumina Insulating Tube.
8.	Ceramic Fibre Insulated Compensating Cable 3/6 Mtrs. long with overall Ceramic Fiber Sleeve.
9.	Quick Release compensated Connectors "R"/"S"/"B" Type.
■	a,b,c are distances from tip to bottom, middle & top sensor elements depending on the design.

TI / GL / 02

THERMOCOUPLES FOR DISTRIBUTOR AND FORE HEARTH

In distributor and fore hearths rear and middle zone most of the glass companies use this simplex small thimble thermocouple. This is the substitute of fibre optic pyrometer. With Pyrometer customer can get only glass surface temperature but using this thermocouple, customer can get glass immersion temperatures. It is commonly used in all container glass industries. We manufacture conditioning zone trilevels and rear /middle zone simplex thermocouples from same batch element with same accuracy, our customer can get relative temperatures with high accuracy.

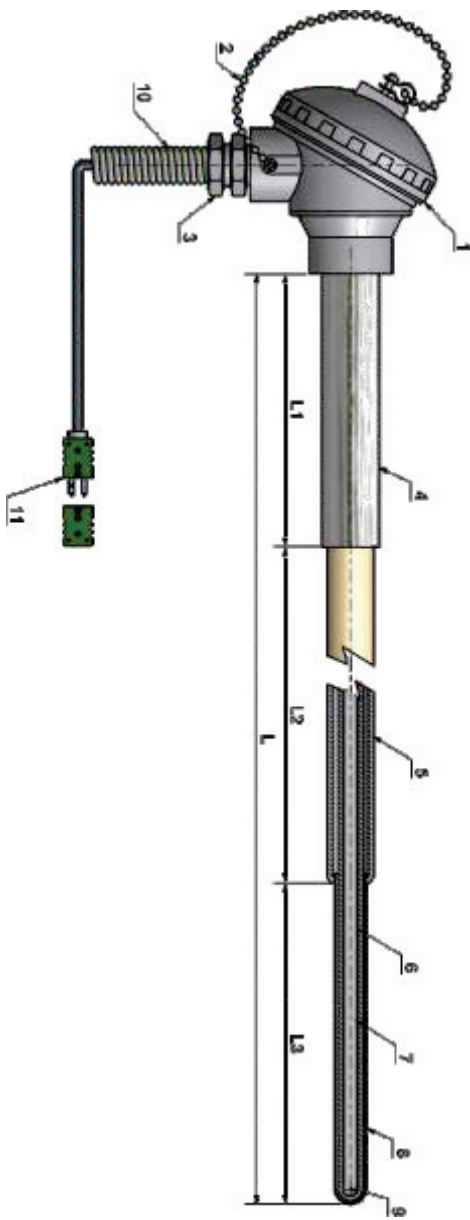

TI / GL / 04

Type	TI/GL/04
Measuring Range	100 to 1600°C.
Sensor Type	"R"/"S"/"B". At three levels at B-Bottom, M-Middle, T-Top.
Protection Sheathing	Recrystallised Alumina KER-710 (C-799) Tube with hole at one end. Special Hardened Platinum / PT Alloy Thimble.
Application	Fore Hearth and Distributor Glass Immersion.

S.No.	Description
1.	SS/Aluminium Connection Head IP-67.
2.	SS Chain.
3.	½" NPT(M) Cable Gland
4.	Holding Tube : (Inconel - 600/SS310)
5.	Recry. Alumina Tube :- OD X ID to be specified.
6.	Inner Tube suitable to Outer Tube.
7.	2 Bore Recry. Alumina Insulating Tube.
8.	Hardened PT/PT Alloy Thimble :- OD X THK. suitable to Inner Tube.
9.	PT-RHPT Thermocouple Element R/S/B type
10.	Ceramic Fibre Insulated Compensating Cable 3/6 Mtrs. long with overall Ceramic Fiber Sleeve.
11.	Quick release compensated connectors "R"/"S"/"B" Type.