



# Temperature Calibrator (CALsys 1500) User's Guide



**TEMPSSENS INSTRUMENTS (I) PVT. LTD. UNIT II**

A-190, Road No.5, M.I.A., Udaipur-313003 INDIA

**Ph. :** +91-294-3500600,

**Fax :** +91-294-3500631

**Email :** tech@tempsens.com

**Web :** www.tempsens.com

## Legal Disclaimer

*The information contained in this document is the property of TEMPSENS.*

*TEMPSENS reserves the right to make changes to this document and to the product described herein without notice. Before installing and using the product, review the latest version of the applicable documentation, which are available from the Tempsens website at:*

*<http://www.tempsens.com/>*

*© 2021 Tempsens Instrument Pvt. Ltd. All Rights Reserved.*

## Document Information

Name	Temperature Calibrator (CALsys 1500) User Manual
Document Version	1.0
Document Code	TS.CS.005
Publish Date	Tuesday, January 4, 2022

# Table of Contents

---

<b>Preface.....</b>	<b>5</b>
Safety Information.....	5
Electrical Safety.....	6
Health and Safety Instructions.....	7
Cautions and Preventions.....	8
Document Conventions.....	8
<b>Chapter 1</b>	
<b>Introduction.....</b>	<b>9</b>
1.1 About CALsys 1500.....	9
1.2 Basic Working Model of CALsys 1500.....	10
1.3 Physical Measurements.....	11
1.4 Wiring Diagram.....	12
1.5 Technical Specifications.....	13
1.6 Technical Specifications.....	14
<b>Chapter 2</b>	
<b>Installation of CALsys 1500.....</b>	<b>18</b>
2.1 Installation.....	18
2.2 Earthing.....	23
2.3 Heater Connection.....	24
2.4 Internal Structure.....	24
<b>Chapter 3</b>	
<b>Operating CALsys 1500.....</b>	<b>25</b>
3.1 Turning On the Unit.....	25
3.2 Heating Up the Source.....	26
3.3 Operating Instructions.....	26
3.4 Cooling Down the Source .....	27

## Chapter 4

<b>Operating Unit Controller.....</b>	<b>28</b>
4.1 Front Panel Layout.....	28
4.2 The temperature Controller.....	28
4.3 Altering the Set Point .....	28
4.4 Monitoring the Controller Status .....	28
4.5 Temperature Units .....	28

## Chapter 5

<b>Digital Communication.....</b>	<b>29</b>
5.1 Digital Communications Wiring.....	29
5.2 Digital Communications Parameters.....	30

## Chapter 6

<b>Software Installation.....</b>	<b>31</b>
6.1 Installation.....	31
6.2 Parameters on main screen.....	31

## Chapter 7

<b>Service &amp; Maintenance.....</b>	<b>33</b>
7.1 Routine Service.....	33
7.2 Replace the Controlling Sensor.....	33
7.3 Replace Solid State Relay.....	33

## Chapter 8

<b>Troubleshooting CALsys 1500.....</b>	<b>35</b>
8.1 CALsys 1500 unit does not turn on.....	35
8.2 CALsys 1500 unit is not stable.....	35
8.3 The temperature of the calibrator does not rise.....	35

<b>Appendix A : Calibration Services .....</b>	<b>36</b>
In House Calibration Facility.....	36

---

On-site Calibration Facility.....	36
Fixed-Point Calibration Facility.....	36
<b>Appendix B : Warranty .....</b>	<b>37</b>
Limit of Liability.....	37
Caution in Using the Product.....	37

# Preface

---

Welcome to the Temperature Calibrator (CALsys 1500) user guide. This guide provides detailed information about all the product options and features, and explains how to use the product and configure basic settings to suit your requirements.

This user manual contains information about the product and its proper use and should be kept in a place where it will be easy to access. This user manual also provides safety precautions in using this product.

## Safety Information

This chapter contains important information for the safety. If the instructions contained are not followed properly, particularly the safety guidelines, it could result in serious personal injury or can cause serious damage to the unit and to the components of system it is connected to. Use the instrument only as specified in this manual. Otherwise, the protection provided by the instrument may be impaired.





Refer to the safety information below and throughout the manual.

In order to assure the device operates safely, the operator needs to act effectively and be conscious of safety problems.

The terms “Warning” and “Caution” have the following definition:

- **"Warning"** indicates conditions or behaviors that could endanger the user.
- **"Caution"** denotes situations or behaviors that may endanger the instrument in use.

The following safety symbols may appear on CALsys 1500 unit:

SYMBOL	DESCRIPTION	SYMBOL	DESCRIPTION
	Risk of Danger. Important information. See Manual		Hazardous voltage. Risk of electric shock
	Caution, Hot Surface		Protective Earth Ground

## Electrical Safety

---

### **WARNING:**

- **Before using this equipment, make sure it is properly grounded. Make sure the ground conductor wire (colored green/yellow) in the main power cable is connected to a protective earth/ground. If the equipment is not properly grounded, the high voltage may flow through the equipment body (chassis). If safety procedures are not followed, SEVERE INJURY OR DEATH may occur.**
  - **Do not remove the panels from the equipment without proper safety measures to avoid internal main power supply voltage hazard.**
- 

Follow these precautions to avoid electric shock or personal injury:

- ⊕ This equipment uses protective earth circuit to ensure that the conductive parts do not store electric charges or conduct electricity if insulation fails
- Before connecting the equipment to the electricity supply, understand the parts of the calibrator with the help of operating manual.
- Use power cables only with appropriate voltage and power rating, and that are approved for usage in your country.
- Replace the main power cable if the insulation is damaged, or if the insulation shows signs of wear and tear.
- DO NOT put the product at the location where access to the main power is blocked.
- DO NOT use an extension cord or adapter plug.
- DO NOT use the product if it operates incorrectly.
- Make sure the power cord does not touch the hot parts of the product.

---

## Health and Safety Instructions

---

 **WARNING: BURN HAZARD - DO NOT touch the well access surface of the unit at high temperature**

---

To avoid possible health and safety concerns, follow these guidelines.

- Wear appropriate protective clothing before using the equipment.
- Operators of this equipment should be adequately trained in the handling of hot and cold items and liquids.
- Do not use the apparatus for jobs other than those for which it was designed, that is, the calibration of thermometers.
- Do not handle the apparatus when it is hot (or cold), without wearing the appropriate protective clothing and having the necessary training.
- Do not drill, modify or otherwise change the shape of the apparatus.
- Do not use the apparatus outside its recommended temperature range.
- After use, do not return the apparatus to its carrying case until the unit has cooled down.
- There are no user serviceable parts inside. When required, contact Tempsens agent for repair.
- Ensure all materials, especially flammable materials are kept away from the hot parts of the apparatus, to prevent fire risk.
- Do not use the product around explosive gas, vapor, or in damp or wet environments.
- Make sure that the space around the product meets minimum space requirements.
- DO NOT turn off the unit at temperatures higher than 350°C. This could create a hazardous situation. Select a set-point less than 100°C and allow the unit to cool before turning it off.
- The top sheet metal of the furnace may exhibit extreme temperatures for areas close to the well access.
- Materials used in this furnace may be irritating to skin, eyes, and respiratory tract. Consult the material manufacturer's Material Safety Data Sheet (MSDS) to learn about those materials before using.







## Cautions and Preventions

To avoid possible damage to the instrument, follow these guidelines:

- Before working inside the equipment, turn the power off and disconnect the power cord.
- DO NOT turn the unit upside down with the inserts in place; the inserts will fall out of the unit.
- Use of this instrument at HIGH TEMPERATURES for extended periods of time requires caution.
- Completely unattended high temperature operation is not recommended for safety reasons.
- DO NOT plug the unit into 230 V if the heater switches and fuse holder reads 115 V. This action will cause the fuses to blow and may damage the instrument.
- Components and heater lifetime can be shortened by continuous high temperature operation.
- DO NOT use fluids to clean out the well.
- Never introduce foreign material into the probe hole of the insert. Fluids and other materials can leak into the calibrator causing damage.
- DO NOT drop or force the probe stems into the well. This type of action can cause a shock to the sensor and affect the calibration.

## Document Conventions

The documentation uses the following conventions.

 Note:	Configuration notes
 Tip:	Recommendations or suggestions
 <b>Important:</b>	Information regarding required or default configuration settings and product limitations
 <b>WARNING:</b>	Critical actions and configuration options
 <b>WARNING:</b>	

## Chapter 1

# Introduction

---

## 1.1 About CALsys 1500

The 'CALsys 1500' has been designed to provide stable and accurate temperature to enable professionals to calibrate Temperature Sensing Devices by comparison method. The 'CALsys 1500' model has been designed to be rugged and easily maintained. This model provides an isothermal enclosure (ceramic block) in which the thermocouple/RTD/Pyrometer can be calibrated against the temperature of the calibrator. For traceable calibration a master calibration sensor should be placed into the metal block alongside the unit under calibration.

The method is widely accepted because the calibrator provides very stable temperature nearing to its controlled point, the Master Thermocouple, which is calibrated by independent Laboratory traceable to National standards, compares the sensor under calibration.

The 'CALsys' models are part of wide range of Laboratory calibrators designed and made by us. Please contact us in case you required more information about our other products.



Front View



Back View

### **WARNING:**

Power is present even if the front panel switch is in the OFF (0) position.

---

## 1.2 Basic Working Model of CALsys 1500

The calibrator controller uses a precision R type thermocouple as a controlling sensor and controls the well temperature with 6 silicon carbide heater. To obtain and maintain a required temperature the controller varies the power to the heater via solid-state relay. There is one electricity driven fan which is situated under the heating chamber for cooling the heater. The CALsys 1500 calibrator was designed for laboratory, moderate cost and ease of operation. With proper use the instrument should provide continued accurate calibration of temperature sensors and devices.

### Warning

- Before using the equipment, read the safety guidelines and operating procedures of the calibrator as described in the of this user manual.
- Do not insert impure materials, metal objects or probes etc. into the block.

The basic working model for CALsys 1500 is as follows:

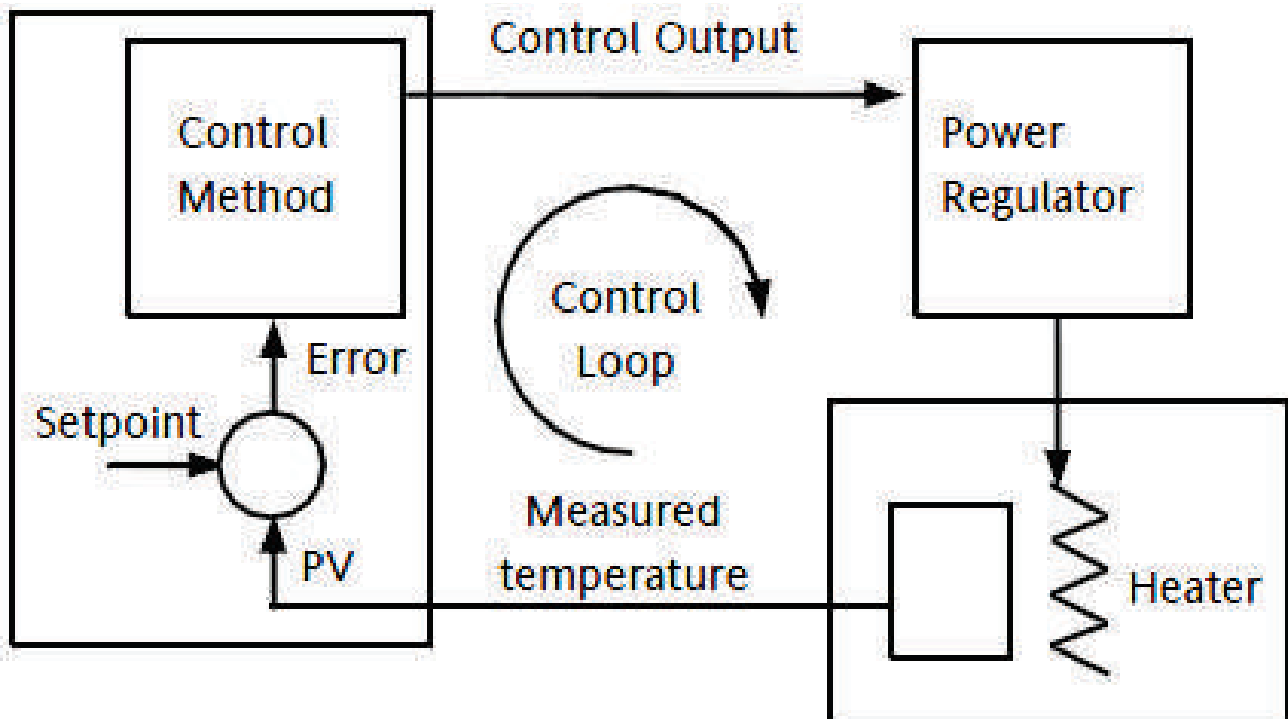

### 1.3 Physical Measurement

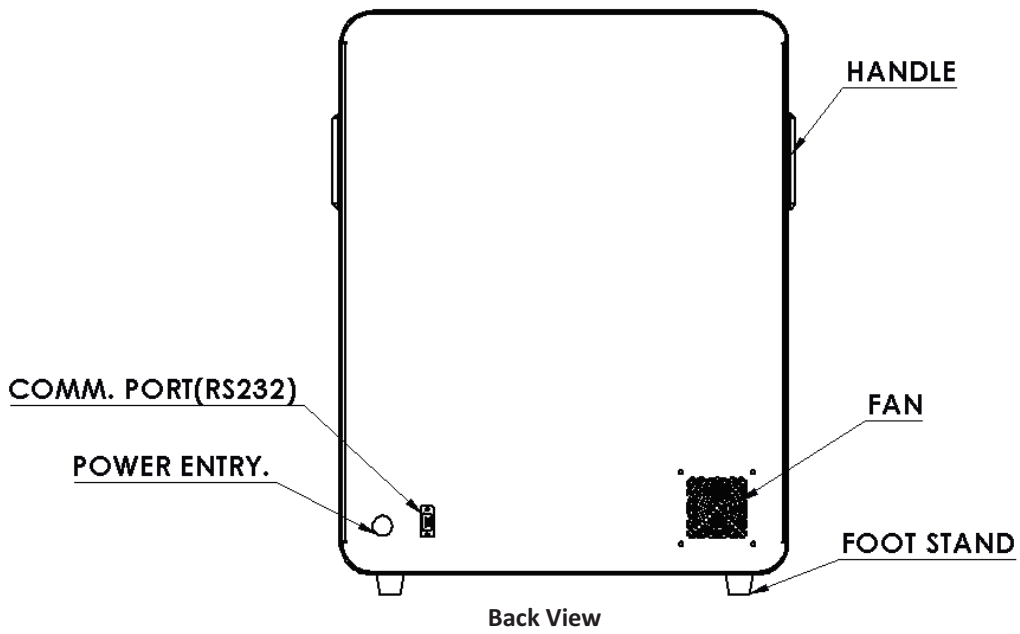
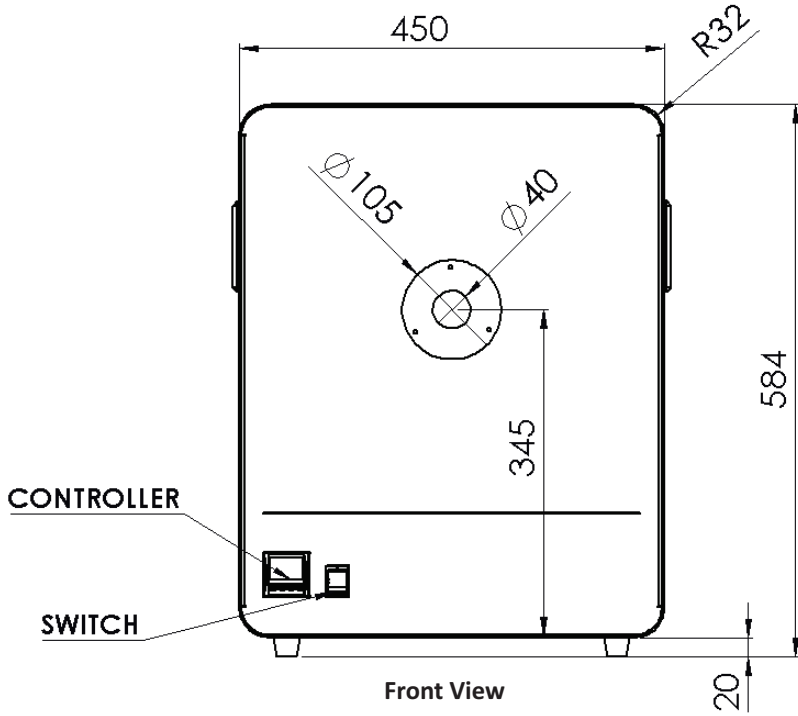

## 1.4 Wiring Diagram

Refer to following figure for CALsys 1500 wiring diagram.

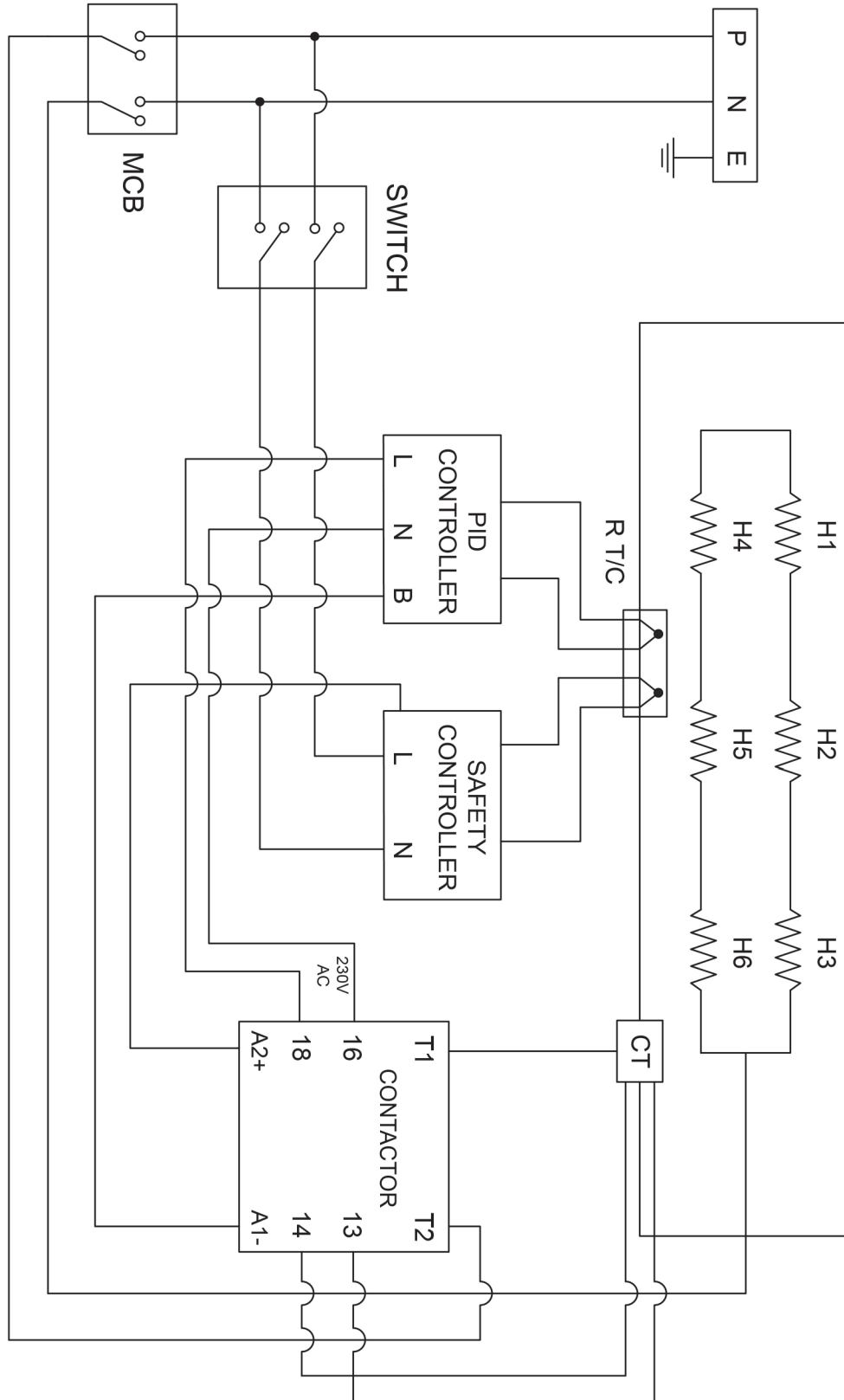

## 1.5 Technical Specification

CALsys 1500BB has the following technical specifications:

PARAMETER	SPECIFICATION
Voltage	230 V AC $\pm$ 10
Power	3 KW
Supply Frequency	50/60 Hz
Temperature Range	500°C to 1500°C
Resolution	0.1 °C (upto 999.9°C above 1.0°C)
Stability	$\pm$ 0.2°C at 500°C $\pm$ 0.3°C at 1000°C $\pm$ 0.5°C at 1500°C
Uniformity	$\pm$ 2.0°C
Cavity type	Silicon Carbide
External Aperture	40 mm dia
Cavity diameter	46 mm(85 mm depth)
Emissivity	0.98( $\pm$ 0.01)
Controlling sensor	Precision R type T\C
Time to reach max. temperature	2 hrs
Operating temperature	20 to 45 °C
Method of controlling	Digital self tuned PID controller (Eurotherm P104 Controller)
Computer interface	RS-232
Dimensions	590(H) x 450(W) x 530(D) mm
Cavity	Diameter 37 x 245mm long (2 x 6 mm & 2 x 8mm)
Weight	Approximate 55 Kg

## 1.5 Technical Specification

CALsys 1500L has the following technical specifications:

PARAMETER	SPECIFICATION
Temperature range	500 °C to 1500 °C
Stability	±0.4°C at 500°C
	±0.6°C at 1000°C
	±1°C at 1500°C
Uniformity	±0.6°C at 500°C
	±0.8°C at 1000°C
	±1.2°C at 1500°C
Controlling sensors	R type duplex
Stabilization time	15 to 20 mins
Immersion depth	140 mm
Insert dimensions	37 mm
Method of Control	Self tuned PID controller
Heating time	2 Hrs
Resolution	1 °C
Display	LCD, °C or °F user-selectable
Size (H x W x D)	590(H) x 450(W) x 530(D) mm
Weight	55Kg
Power requirements	230 VAC, 3.0 KW(50 Hz)
Computer interface	Ethernet port (CALsys 1500L Autocal), RS - 232(CALsys 1500L)
Calibration	Accredited calibration certificate provided
Environmental operating conditions	0 °C to 40 °C, 0 % to 90 % RH (non-condensing)
Specifications valid in environmental conditions	13 °C ... 33 °C

## Chapter 2

# Setting up CALsys 1500

---

## 2.1 Installation

Place the calibrator on a flat surface with at least 10 inches of free space around the instrument. Overhead clearance is required.

DO NOT Place this unit under a cabinet or structure. Plug the power cord into a grounded mains outlet located on the controlling unit rear panel. Observe that the nominal voltage corresponds to that indicated in the [Technical Specifications](#) in [Chapter 1](#) of this user's guide.

## 2.2 Optimal Environmental Conditions

Although the instrument has been designed for optimum durability and trouble-free operation, it must be handled with care. The instrument should not be operated in an excessively dusty or dirty environment. Refer to [Chapter 8, Service & Maintenance](#) in this user's manual for routine service and cleaning recommendations.

The instrument operates safely under the following conditions:

- Temperature range: 5°C - 50°C (41°F - 122°F)
- Ambient relative humidity: 15 - 50%
- Pressure: 75kPa - 106kPa
- Mains voltage within  $\pm 10\%$  of nominal
- Vibrations in the calibration environment should be minimized
- Altitude less than 2000 meters



## 2.3 Unpacking and Initial Inspection

CALsys 1500 is packed in custom-designed packaging to send out your unit. Unpack the furnace carefully. Inspect the unit after unpacking for any signs of damage, and confirm that your delivery is in accordance with the packing note. If you find any damage to the unit or an item is missing, notify TempSENS immediately.

The following accessories are included in the package:

- CALsys 1500L/BB
- Heating Chamber
- Heaters (Silicon Carbide)
- RS-232 Cable
- Ceramic Cavity/optional block for dry block
- Bolts
- Collar
- Clamps
- Manual
- Certificates
- Insulation Wool
- R Type master thermocouple



CALsys 1500L/BB



Heating Chamber



Heaters



Insulation Wool

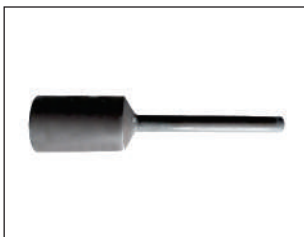

Cavity



RS-232



Optional Block

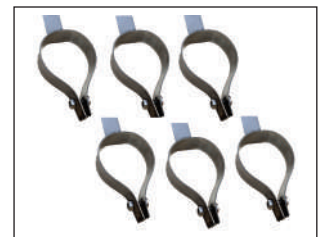

Clamps



Bolts

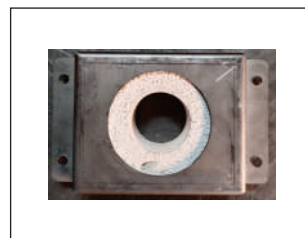

Collar



Thermocouple

---

## 2.5 Operating Instructions

1. Please open the wooden box carefully and take out the operating manual from the box and read carefully.
2. Take out the temperature calibrator unit carefully and keep it at suitable place.
3. Install inner chamber as instructed in [Installation of CALsys 1500](#) in [Chapter -3](#) of this user guide.
4. Connect the power plug to the mains.
5. Turn the switch ON, and observe the display on the controller. The display shows that the calibrator is ready for use.
6. Keep the switch in the ON position
7. Ensure the ceramic insert/ceramic cavity is properly inserted in the calibrator.



Ceramic Cavity for CALsys 1500BB



Ceramic Block for CALsys 1500L



Note:

- Ceramic insert or ceramic cavity should be removed from the calibrator when it will reach ambient temperature.
  - Use either block or ceramic cavity (DO NOT use them together).
  - Always use safety gloves while handling the calibrator.
-

## Chapter 3

# Operating CALsys 1500

### 3.1 Turning ON the unit

Plug the CALsys 1500 power cord into mains outlet of the proper voltage, frequency and current capability. Typically this will be (230 VAC±10, 50/60 Hz). Using the “ON/OFF” (for heater supply) switch located at front side responsible for heating of furnace. The furnace will turn on and begin to heat the previously programmed temperature set-point.

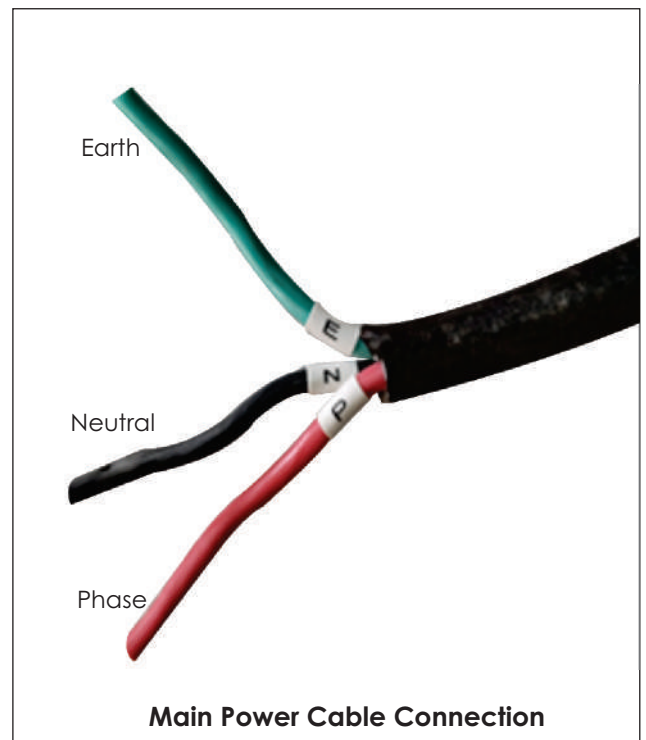

## 3.2 Heating up the source

Press “UP” or “DOWN” key of controller to change the set-point value. When the set-point temperature is changed the controller will switch the furnace heater on or off to raise or lower the temperature. The displayed temperature will gradually change until it reaches the set-point temperature. The furnace may require time to reach the set-point depending on the span. An another 25 to 30 minutes is required to stabilize the furnace with  $\pm 1.5^{\circ}\text{C}$  of the set-point.

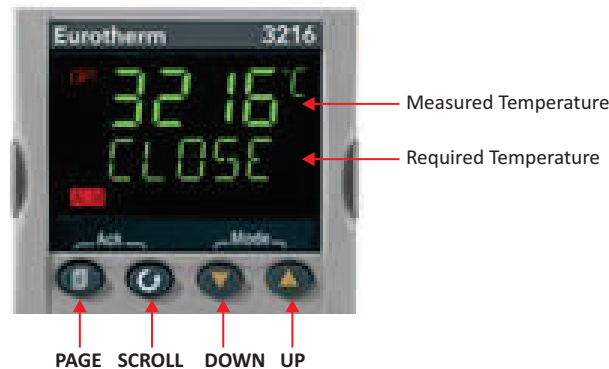

### ! Important:

- All other controller parameters are company set and locked. It is recommended not to change them.
- When the source is operated at any temperature above ambient, the front face and plate become hot.
- Always put the fan in “ON” Condition and do not switch the “Mains” off Directly, First set the controller to  $0^{\circ}\text{C}$  and then wait until the unit is not cooled below  $350^{\circ}\text{C}$ .

## 3.3 Operating Instruction

1. After the complete installation.
2. Connect the 'CALsys 1500' to a suitable power supply. ON the Mains switch located at back side with power entry.
3. Set the desire temperature value in PID by using UP & Down key.
4. Aim the reference (Master) standard infrared temperature sensor to the target area.
5. PV (Present value) display in controller will gradually rise until it reaches the set point temperature. The controller takes some time to reach the set-point depending on the span.  
Furnace is stable when PV is equal to SV (Set Value).
6. Master sensor takes some time to reach the set point temperature and stable at temperature near about controller set temperature.

- 
7. When temperature of the master and UUC (Unit under calibration) are stable record the readings of master sensor.
  8. Compare the UUC reading with the master's reading & find out the error by comparison method.
  9. Reset the controller and / or repeat the calibration for another calibration point or for another sensor.
  10. When the calibration is complete, reset the controller to 0°C & wait until the unit has cooled to below 350°C, before moving the 'CALsys 1500 to new location the 'CALsys 1500' must be cooled below 350°C before it can be put back into its carrying case.



Note:

- Ceramic Insert should be of required hole size so that the hole size is suitable for sensor under calibration.
- Check that all sensors (test and master) are immersed at same depth in insert (ceramic block).
- Plan the calibration point by gradually increasing temperature, then set the controller accordingly. This method will save the time.
- Take the reading of sensors (master and test) at stable temperature with the help of digital multi-meter, or by using Tempsens' TEMPMET 08 or TEMPMET 09 for reading RTD or TC sensor.

---

### 3.4 Cooling Down the Source

- Before transporting the ceramic block, ensure that the temperature of black body has cooled sufficiently.
- If you require black body to cool quickly, set the temperature to the room temperature (ambient temperature).
- Always cool the heated instrument to ambient temperature before disconnecting it from the mains, switching it OFF, or removing the temperature sensor or test item.
- Always keep the heated instrument supervised and under observation until it cools down sufficiently.

## Chapter 4

# Operating Unit Controller

---

### 4.1 Front Panel Layout

The following image shows the front panel of CALsys 1500.

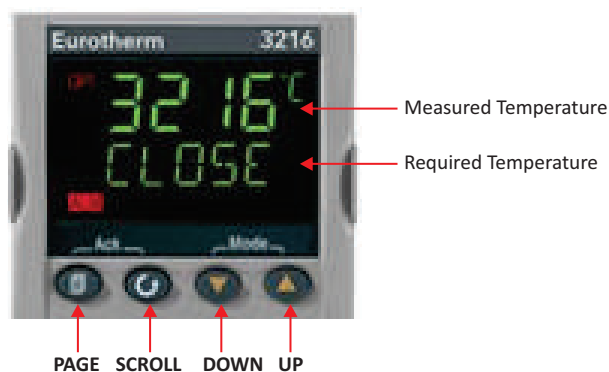

### 4.2 The Temperature Controller

The upper display of the controller indicates the measured temperature, the middle display indicates the desired temperature or set point and lower display shows output power demand.

### 4.3 Altering the Set point

To change the set point of the controller simply use the UP and DOWN keys to raise and lower the set point to the required value. The lower display changes to indicate the new set point.

### 4.4 Monitoring the Controller Status

A row of beacons indicate the controllers status as follows,

OP1 Heat Output

OP2 Cool Output (only for models which operate below 0°C)

REM This beacon indicates activity on the PC interface

### 4.5 Temperature Units

Momentary pressing of the Scroll key will show the controller units °C or °F.

## Chapter 5

# Digital Communication

Digital Communication allows the controller to communicate with a PC or a networked computer system through RS-232 (or EIA232) protocol. RS-232 (or EIA232) is a standard communication protocol for linking computer and its peripheral devices to allow serial data exchange. RS-232 communication is not available if Remote Set point is fitted. The cable screen should be grounded at one point only to prevent earth loops.

## 5.1 Digital Communications Wiring

To use EIA232 (or RS-232), the PC will be equipped with an EIA232 port, usually referred to as COM 1. To construct a cable for EIA232 operation use a three core screened cable. The terminals used for EIA232 digital communications are listed in the table below. Some PC's use a 25-way connector although the 9 way is more common.

STANDARD CABLE COLOR	PC SOCKET PIN NO.		PC FUNCTION*	INSTRUMENT TERMINAL	INSTRUMENT FUNCTION
	9 WAY	25 WAY			
White	2	3	Receive (RX)	HF	Transmit (TX)
Black	3	2	Transmit (TX)	HE	Receive (RX)
Red	5	7	Common	HD	Common
Link Together	1	6	Received line signal detect		
	4	8	Data terminal ready		
	6	11	Data set ready		
Link Together	7	4	Request to send		
	8	5	Clear to send		
Screen		1	Ground		

\*These are the functions that are normally assigned to socket pins. Check your PC manual to confirm.

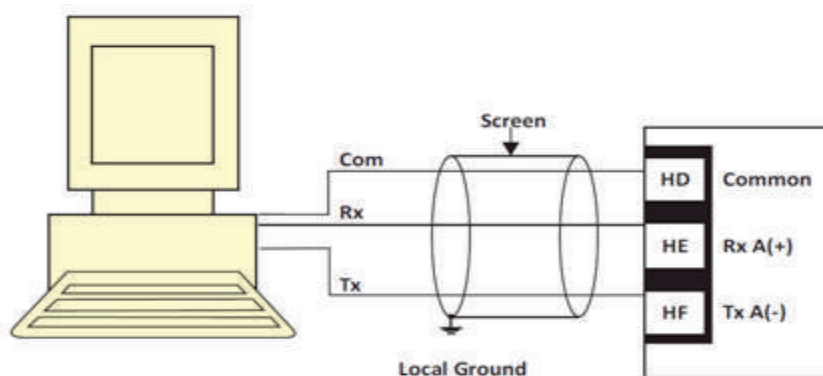

## 5.2 Digital Communications Parameters

The following table shows the available parameters.

DIGITAL COMMUNICATION LIST (COMFITS)						
NAME	SCROLLING DISPLAY	PARAMETER DESCRIPTION	VALUE		DEFAULT	ACCESS
ID	MODULE IDENTITY	COMMUNICATION IDENTITY	none	NO MODULE FITTED	AS ORDER CODE	CONF L3 R/O
			R232	RS232 MODBUS INTERFACE		
			R485	EIA485 MODBUS INTERFACE		
			R422	EIA422 MODBUS 3216 ONLY		
			DCP	REMOTE SET-POINT INPUT. IF FITTED THIS ID REPLACES THE ABOVE AND NO FURTHER PARAMETERS ARE SHOWN		
ADDR	COMMUNICATION ADDRESS	COMMUNICATION ADDRESS OF THE INSTRUMENT	1 TO 254		1	L3
BAUD	COMMUNICATION BAUD RATE	COMMUNICATION BAUD RATE	1200	1200	9600	
			2400	2400		
			4800	4800		
			9600	9600		
			19.20	19.20		
PRTY	COMMUNICATION PARITY	COMMUNICATION PARITY	none	NO PARITY	NONE	
			Even	EVEN PARITY		
			ODD	ODD PARITY		
DELAY	RX/TX DELAY TIME	TO INSERT A DELAY BETWEEN RECEIVER (RX) AND TRANSMITTER (TX) TO ENSURE THAT DRIVERS HAVE SUFFICIENT TIME TO SWITCH OVER.	OFF	NO DELAY		CONF L3 R/O
			On	FIXED DELAY APPLIED		
RE TRAN	COMMS RETRAN MISSION	MASTER COMMS BROADCAST PARAMETER SEE SECTION 15.2.1	none	NONE	NONE	
			WSP	WORKING SETPOINT		
			PU	PROCESS VARIABLE		
			OP	OUTPUT DEMAND		
			ERR	ERROR		
REGAD	COMMS RETRAN MISSION ADDRESS	PARAMETER ADDED IN SLAVE ADDRESS TO WHICH THE MASTER COMMUNICATION VALUE WILL BE WRITTEN	0 TO 9999			



## Chapter 6

# Software Installation

The provided Tempsens software offers possibilities to connect furnace temperature bath and change set point, maximum time span, view real time graph and evaluate measuring data.

## 6.1 Installation

Install the calibration software using the installation guide file. After installing the software, start the application. CalSoft Tempsense Instruments screen appears, as shown in figure 1.

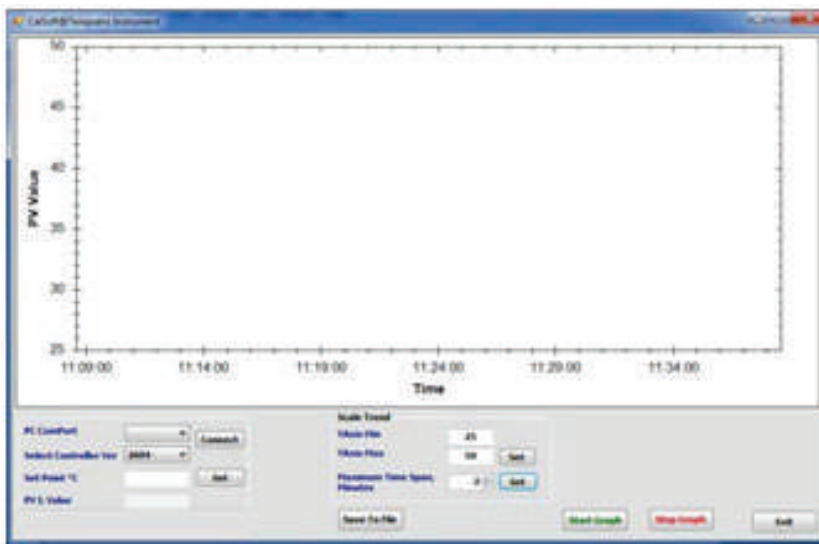

Figure 1 - Main screen



Figure 2 - PC ComPort



Figure 3 - Controller Version

## 6.2 Parameters on Main Screen

Communication between the furnace and the software is implemented via RS-232 cable connected between the furnace and the PC serial port. This enables the acquisition and recording of data, as well as the transfer of commands from the software application to the Tempsens furnace.

To communicate between the furnace and software application, select correct **COM port** (as shown in *Figure 2*) and Controller Version (**3216**) (as shown in *Figure 3*), and then click **Connect**.

To set the temperature of furnace as per your requirement, type the required temperature in **Set Point (°C)** field, and click **Set**.

PVI Value displays the current present value of furnace temperature.

The **Scale Trend** section enables you to configure **Y-Axis Min** (minimum value: **0**), **Y-Axis Max** (maximum value: **1500**), **Maximum Time Span** of data logging up to 120 minutes, and then click the **Start Graph** button. After completing the task, click **Save To File** to save settings to file. See *Figure 4*.

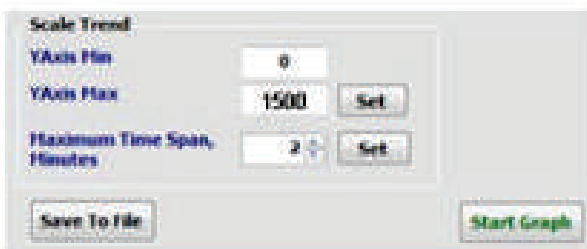
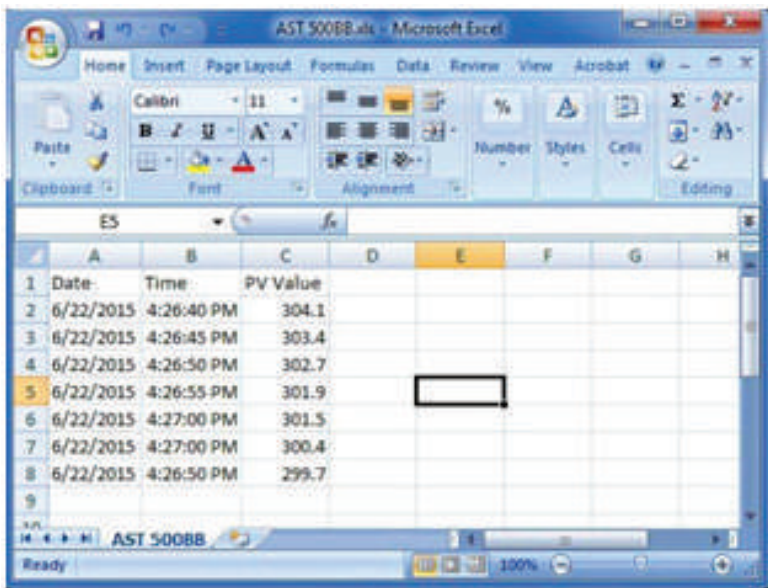

Figure 4 - Scale Trend Window

File will be stored in **.xls** format to save previous record. See *Figure 5*.



The image shows a Microsoft Excel spreadsheet window titled "AST 500BB.xls - Microsoft Excel". The spreadsheet has a table with the following data:

	A	B	C	D	E	F	G	H
1	Date	Time	PV Value					
2	6/22/2015	4:26:40 PM	304.1					
3	6/22/2015	4:26:45 PM	303.4					
4	6/22/2015	4:26:50 PM	302.7					
5	6/22/2015	4:26:55 PM	301.9					
6	6/22/2015	4:27:00 PM	301.5					
7	6/22/2015	4:27:00 PM	300.4					
8	6/22/2015	4:26:50 PM	299.7					
9								

Figure 5 - Record in .xls Format

## Chapter 7

# Service & Maintenance

---

### 7.1 Routine Service

Turn the electricity supply off before attempting any cleaning operation. The only moving part is the fan. That has sealed-for-life bearings. Depending on the environment in which it is used, periodic cleaning is recommended. Cleaning may be accomplished by the use of a small dry paint brush. The instrument should be periodically checked to ensure it is in good order both mechanically and electrically.

### 7.2 Replace the Controlling Sensor

Replacement of the controlling T/C Sensor is carried out as follows:

1. Make sure that the Calibrator Unit is not connected to the mains supply.
2. Remove the front and back cover of the Calibrator. Refer Page 17.
3. Remove the T/C from the heating chamber present inside by unscrewing the Screw fitted in the fitting  
Refer Page 18.
4. Fit the new T/C.
5. Reconnect the new T/C to the connector block (M & S Plate).
6. Replace the cover.

### 7.3 Replace Solid State Relay

1. Disconnect the Calibrator Unit from the electrical supply.
2. Remove the cover of the furnace.
3. Locate the solid state relay.
4. Disconnect the wires, noting their position.
5. Remove the faulty relay and replace it with a new one.
6. Tighten the fixing screws.
7. Refit the wires has been noted in step 4.
8. Replace the cover.
9. Reconnect the furnace to the electrical supply.

**Note:**

- The calibration instrument has been designed with the utmost care. Ease of operation and simplicity of maintenance have been a central theme in the product development. Therefore, with proper care the instrument should require very little maintenance. Avoid operating the instrument in an oily, wet, dirty, or dusty environment.
  - If the outside of the instrument becomes soiled, it may be wiped clean with a damp cloth and mild detergent. Do not use harsh chemicals on the surface which may damage the paint.
  - It is important to keep the calibrator clean and clear of any foreign matter. DO NOT use chemicals to clean the calibrator.
  - Avoid knocking or dropping the instrument.
  - If a hazardous material is spilt on or inside the equipment, the user is responsible for taking the appropriate decontamination steps as outlined by the national safety council with respect to the material.
  - If the mains supply cord becomes damaged, replace it with a cord with the appropriate gauge wire for the current of the instrument. If there are any questions, contact tempsens.
-

## Chapter 8

# Troubleshooting CALsys 1500

---

### 8.1 CALsys 1500 unit does not turn on

If the CALsys 1500 unit does not turn on or operate as usual, check if the fuse is broken, and replace the fuse if necessary. If the fuse breaks repeatedly, contact Tempens for technical support.

### 8.2 The CALsys 1500 unit is not stable

If the CALsys 1500 is not stable or the temperature varies too often, the control parameters might have been modified. If this happens, contact Tempens for technical support.

### 8.3 The temperature of the calibrator does not rise

If the temperature of the Calibrator Unit does not rise, ensure the following:

- (a) The power cord is tightly fitted at the power entry location on the Calibrator Unit.
- (b) The switch should be in ON position.

If the temperature of the Calibrator Unit still does not rise even after you have inspected and fitted the power cord and power switch, the reason can be one of the following:

- The heating element is not firmly closed. If the heating element is open, close it properly.
- The thermocouple is not firmly closed. If the thermocouple is open, close it properly.
- The Controller Unit may be not display correct reading.
- The SSR is damaged.

If the Calibrator Unit does not function properly, contact Tempens immediately for technical support.

# Appendix A: Calibration Services

Tempens Calibration Center is an independent unit of Tempens instruments (I) Pvt. Ltd, having laboratories at Udaipur, Vadodara & Bangalore. It is accredited for wide range of temperature calibration services.

It is the only private sector Laboratory in the country with accredited Fixed Point Temperature Calibration Facilities. The lab has highly stable calibration furnaces, measuring instruments and accurate master sensors traceable to National and International Standards.

The calibration center functions as per ISO 17025 / NABL standards. Calibration of contact type sensors can be made in temperature range of -196°C to 1600°C and Calibration of non-contact type sensors can be made in temperature range 0°C to 2900°C. Further the laboratory is accredited for onsite temperature calibration.

The lab offers both at Lab & On-Site Calibration of Furnace/Bath from -80°C to 1600°C and Black Body Calibration from 50°C to 1700°C. Furnace/Chamber Calibration (TUS) with multiple sensors from -80°C to 1200°C is also in the scope of the lab.

## In House Calibration Facility

QUALITY MEASURED / INSTRUMENTS	TEMPERATURE RANGE	CALIBRATION & MEASUREMENT CAPABILITY
Contact Type RTD, Thermocouples Thermometers	-196°C	0.05°C
	-80 to -38°C	0.03°C
	-38°C to 0°C	0.03°C
	>0°C to 140°C	0.04°C
	>140°C to 250°C	0.04°C
	>250°C to 650°C	0.12°C
	>650°C to 1200°C	1.30°C
	>1200°C to 1600°C	2.60°C
Non-Contact Type Pyrometer	0°C to 250°C	1.5°C
	>250°C to 500°C	2.4°C
	>500°C to 1500°C	2.5°C
	>1500°C to 1700°C	3.2°C
	>1700°C to 2900°C	4.0°C

## On-site Calibration Facility

QUALITY MEASURED / INSTRUMENTS	TEMPERATURE RANGE	CALIBRATION & MEASUREMENT CAPABILITY
Contact Type RTD, Thermocouples Thermometers	-25°C to 0°C >0°C to 140°C >140°C to 250°C >250°C to 650°C >650°C to 1200°C	0.07°C 0.04°C 0.09°C 0.12°C 1.30°C
Non-Contact Type Pyrometer	0°C to 250°C >250°C to 500°C >500°C to 1200°C	1.50°C 2.40°C 2.5°C
Multipoint Position Calibration of Chamber, Oven, Furnaces (Thermal Mapping(TUS))	-80°C to 200°C >200°C to 1200°C	2.8°C 4.1°C

## Fixed-point Calibration Facilities

QUALITY MEASURED / INSTRUMENTS	TEMPERATURE RANGE	CALIBRATION & MEASUREMENT CAPABILITY
Calibration of SPRT/PRTS/thermocouple and so on.	Triple Point of Water (0.01°C) Melting Point of Gallium (29.7646°C) Freezing Point of Tin (231.928°C) Freezing Point of Zinc (419.527°C) Freezing Point of Aluminum (660.323°C)	0.0038°C 0.0065°C 0.0065°C 0.0071°C 0.0075°C
Calibration of Thermocouple at Secondary Fixed Point	Melting Point of Gold (1064.18 °C) >1500°C to 1700°C >1700°C to 2900°C	0.72°C 2.5°C 3.2°C 4.0°C
	Melting Point of Palladium(1554.8	0.83°C

# Appendix B: Warranty

---

This instrument has been manufactured to exacting standards and is warranted for twelve months against electrical breakdown or mechanical failure caused through defective material or workmanship, provided the failure is not the result of misuse. In the event of failure covered by this warranty, the instrument must be returned, carriage paid, to the supplier for examination and will be replaced or repaired at our option.

FRAGILE CERAMIC AND/OR GLASS PARTS ARE NOT COVERED BY THIS GUARANTEE

INTERFERENCE WITH OR FAILURE TO PROPERLY MAINTAIN THIS INSTRUMENT MAY INVALIDATE THIS GUARANTEE

## Limit of Liability

TEMPESENS is not liable for any damages that arise from the use of any examples or processes mentioned in these Specifications are subject to change without notice.

## Caution in Using the Product

TEMPESENS PRODUCTS ARE INTENDED FOR USE BY TECHNICALLY TRAINED AND COMPETENT PERSONNEL FAMILIAR WITH GOOD MEASUREMENT PRACTICES.

IT IS EXPECTED THAT PERSONNEL USING THIS EQUIPMENT WILL BE COMPETENT WITH THE MANAGEMENT OF APPARATUS WHICH MAY BE POWERED OR UNDER EXTREMES OF TEMPERATURE, AND ARE ABLE TO APPRECIATE THE HAZARDS WHICH MAY BE ASSOCIATED WITH, AND THE PRECAUTIONS TO BE TAKEN WITH, SUCH EQUIPMENT







[www.tempsens.com](http://www.tempsens.com)

**TEMPSENS INSTRUMENTS (I) PVT. LTD.**

Tempsens Instruments (I) Pvt. Ltd. U# I  
B-188A, Road No.5, M.I.A., Udaipur-313003 (Rajsthan) INDIA

**Ph. : +91-294-3507700, Fax : +91-294-3507731**

**Email : [info@tempsens.com](mailto:info@tempsens.com)**